



## CASA W5 SMART

Installation, commissioning and maintenance instruction

# Contents

## Technical Guide

for design engineers, installation engineers and service personnel

The section 1 describes the **high lights of the unit**.

All information for **mechanical installation** is found from section 2.

Instructions for **basic commissioning** is found from section 3.

Units periodically **maintenance and service** is described in section 4.

If a **malfunction or alarm** occurs the instructions are found from section 5.

All **technical data** is found from section 7.

<b>Important information</b> .....	<b>3</b>	<b>4. Service</b> .....	<b>18</b>
<b>1. General Description</b> .....	<b>4</b>	4.1 Service reminder .....	18
1.1 Enclosure .....	4	4.2 To open the ventilation unit .....	18
1.2 Fans .....	4	4.3 Filter .....	18
1.3 Filter .....	4	4.4 Heat exchanger .....	18
1.4 Heat exchanger.....	4	4.5 Fans .....	18
1.5 Temperature .....	4	4.6 Other servicing.....	18
1.6 Protective functions .....	5	<b>5. Alarms and Troubleshooting</b> .....	<b>20</b>
1.7 Automatic energy saving system .....	5	5.1 Alarm, cooker hood .....	20
<b>2. Installation</b> .....	<b>6</b>	5.2 Alarm, control panel .....	20
2.1 Ventilation unit installation site .....	6	5.3 Troubleshooting .....	20
2.1.1 Wall mounting .....	6	<b>6. List of components</b> .....	<b>22</b>
2.1.2 Ceiling mounting .....	7	<b>7. Technical data</b> .....	<b>23</b>
2.1.3 Mounting on a base .....	7	7.1 Fan outputs (EN 13141-4).....	23
2.2 Condensate discharge.....	8	7.2 Outputs of the components .....	24
2.3 Ducts .....	8	7.3 Acoustic data .....	25
2.4 To seal around duct penetration collars .....	8	7.4 Electrical wiring diagram .....	26
2.5 Electric and control cables.....	9	7.4.1 Ventilation units.....	26
2.6 Installation of the Smart control panel.....	10	7.4.2 Control functions with accessories .....	28
<b>3. Commissioning</b> .....	<b>12</b>	7.5 Control diagram .....	30
3.1 Air flows .....	12	7.6 Dimensions .....	31
3.1.1 Setting the basic air flows .....	12	7.7 Weights .....	31
3.1.2 Travelling .....	12	7.8 Ventilation unit codes .....	32
3.1.3 Maximum automatic boost .....	12	7.9 Accessories for installation .....	33
3.2 Commissioning external equipment .....	12	<b>8. Commissioning form</b> .....	<b>34</b>
3.2.1 Digital switch input (DI).....	13		
3.2.2 Control inputs (AI) .....	13		
3.2.3 Relay outputs (DO).....	13		
3.2.4 Control outputs (SEC/SEM – AO4).....	13		
3.3 Smart functions .....	14		
3.3.1 Shortcuts .....	14		
3.3.2 Summer mode .....	14		
3.3.3 Cooker hood function.....	14		
3.3.4 Central vacuum function.....	15		
3.3.5 Fireplace function .....	15		
3.3.6 Automatic Home/Away/Boost system.....	15		
3.3.7 Automatic humidity system.....	15		
3.3.8 Automatic air quality control.....	16		
3.3.9 Temperature boost.....	16		
3.4 Heating/cooling .....	17		
3.5 Anti-frost protection .....	17		
3.6 Restoring factory settings.....	17		
3.7 Changing the service code .....	17		
3.8 Use .....	17		

**NOTE! The manual's original language is Finnish.**



## Important information

This document is intended for everyone involved in the installation work for or the use of a Swegon CASA ventilation unit. Read Instructions for Use before you use the ventilation unit. Save the Instructions for Use for future use. This document is available in our website.

This appliance can be used by children aged from 8 years and above and persons with reduced physical, sensory or mental capabilities or lack of experience and knowledge if they have been given supervision or instruction concerning use of the appliance in a safe way and understand the hazards involved. Children shall not play with the appliance. Cleaning and user maintenance shall not be made by children without supervision.

### Installation and commissioning

Only qualified personnel should carry out installation, configuration and commissioning. Only a qualified electrician is allowed to make electrical installations in accordance with national regulations.

The national standards and regulations dealing with unit installation, configuration and commissioning must be followed.

Do not use the ventilation unit until all work that produces large quantities of dust or other impurities has been completed.

The duct connections of the ventilation unit must be covered by lids until it is mounted at its final location.

Make sure that the ventilation unit, filters and ducts are clean and that there are no loose objects in them before you commission the ventilation system.

### Electrical work and connections

If you carry out voltage tests, measure the electrical insulation resistance at various points or perform other remedial measures that could damage sensitive electronic equipment, you must first isolate the ventilation unit from the electrical supply grid.

It is recommended that all Smart ventilation units should be equipped with a surge protection device and a residual current circuit breaker. Comply with local electrical safety regulations.

If the supply cord is damaged, it must be replaced by the manufacturer or its service agent or a similarly qualified person in order to avoid a hazard.

### Drying laundry

A tumbler dryer of extract air type or a drying cabinet must not be connected to the system due to the high moisture content in the air it discharges.

### Models with water-based air heater

When there is a water-based heater in the ventilation system the system should be equipped with damper in outdoor air duct so that the air heater cannot freeze during a power failure and unit freezing protection works correctly.

### Condensation

The surface temperature of the ventilation unit can drop down to low during periods of extremely low outdoor temperature and depending on the moisture content of the air surrounding the unit, moisture may condense on the surface. Condensation should be taken into account when choosing furnishings that are to be installed in the vicinity of the ventilation unit.

### To open the ventilation unit for service

Always isolate the ventilation unit's power supply cable before you open the inspection door! Wait a few minutes before you open the inspection door so that the fans are stopped and electrical heaters are cooled.

There are no components inside the electrical box that can be serviced by the user. In case of malfunction, do not restart the ventilation unit before the cause of the fault is identified and fixed.

### Filters

The ventilation unit must not be operated without filters! Use only original Swegon filters. Find the correct filter in the section "Technical data".

### Warranty conditions

Warranty conditions are included in delivery of the unit as a separate document.

### Declaration of conformity

Link to the declaration of conformity:



casahelp.fi

**Included in the delivery:**

- Air handling unit
- Wall mounting bracket
- Adjustment foot (2 kpl)
- Condensate discharge tube
- Instructions for Use (FI, SE, EN + NO, DE)
- Installation, commissioning and maintenance instruction (FI + SE)

**Standard connections:**

- Power supply cable with mains plug
- Modular cable with RJ9 connector (1.5 m)
- Free configurable I/O contacts for connection of accessories (2 pcs.)

**Accessories:**

- Smart user panel
- Modular cable, 20 m, with adapter
- SEC: IO-extension cable with Modbus RTU (single point connector)
- SEM: IO-extension module with relay and Modbus RTU (in and out connectors)
- Duct mounted water heating/cooling coils
- Duct mounted electrical heater
- Smart sensors (RH, CO<sub>2</sub>, VOC)
- Constant duct pressure kit
- Smart Access Mobile Interface

# 1. General Description

The most important function of the ventilation system is to ensure clean and fresh indoor air and to remove moisture. The air in the home should be changed at a continuous and sufficient rate to ensure a pleasant indoor climate and avoid damage to building elements caused by dampness. The ventilation unit should be stopped only while service work is in progress.

## 1.1 Enclosure

The ventilation unit conforms to enclosure class IP34 when the cover is closed.

## 1.2 Fans

The Swegon CASA W5 is equipped with energy-efficient fans with EC motors, advantageous in that their speed is variably controllable and their efficiency is high even when they operate in the lower speed range.

The fans can be controlled in four operating modes from a Smart control panel or in three operating modes from a compatible Swegon CASA cooker hood:

- **Boost** = large airflow is used when the ventilation requirement increases, e.g. for cooking, taking a sauna, showering or drying laundry.

- **Home** = normal airflow. Guarantees that there is sufficient fresh indoor air for the home and the building construction.
- **Away** = low airflow. Reduces power consumption when the ventilation requirement in the home is small.
- **Travelling** = very low air flow and lower supply air temperature. Used when no one is present in the home. (Can only be selected from a Smart control panel.)

The unit's weekly timer has four programs that can switch in the various fan modes at the preset times. On the unit with electric reheating, you can also select the required temperature of the supply air. Even when the ventilation unit is being controlled with the weekly timer, it is always possible to change the fan mode from a control panel or a cooker hood.

You can select an airflow boost time of 30, 60 or 120 minutes or continuous boost from a Smart control panel. When the unit is controlled from a cooker hood, the fan's airflow boost time is 60 minutes. You can select a damper open time of 30, 60 or 120 minutes.

## 1.3 Filter

The ventilation unit is equipped with supply air filter according to filter class ISO ePM1 50% (F7) and with extract air filter according to filter class ISO coarse (G3). The need of filter replacement is indicated on the control panel and on a CASA Smart cooker hood.

## 1.4 Heat exchanger

The counter-flow plate heat exchanger in W5 is manufactured with aluminium fins and provides a high degree of efficiency, up to 85 %. The incoming and outgoing air flows in a counter-flow plate heat exchanger use separate channels. Thanks to this the heat exchanger does not return any odours or any moisture back into the room air. The heat exchanger can be easily removed from the unit for inspection and servicing.

## 1.5 Temperature

The user sets the required value for minimum supply air temperature, and the ventilation unit then strives to reach this temperature if possible. Swegon recommends that the supply air temperature is set between 15–20 °C and the factory setting is 17 °C, which is sufficient for draught-free ventilation. The supply air temperature should be 3–4 °C lower than the room temperature, so that the supply air mixes fully with the room air.

Remember the following when setting the supply air temperature:

- A high temperature setting will also increase the ventilation unit's power consumption.
- A low temperature setting, for example, 14 °C, can cause condensation to collect in the system.
- The ventilation unit cannot cool the supply air without an air cooler (duct coil), which is available as an accessory.

W5's intelligent summer function helps to maintain the home's indoor air comfort even during hot summer days. Very economical comfort coolness can be produced

almost free of charge by utilising the difference between indoor and outdoor temperatures and the heat exchanger intelligently. The heat exchanger takes care of the cool indoor air during hot summer days and cools the incoming outdoor air. At night the air passes the heat exchanger and the home is cooled with fresh outdoor air. This is managed by an advanced automatic system.

## 1.6 Protective functions

### The heat exchanger's freeze protection

W5's defrosting function guarantees continuous and balanced ventilation in the home even during extreme conditions. If there is a risk of the heat exchanger in the ventilation unit freezing, the preheater is activated and the speed of the fans is changed and in doing so the heated extract air prevents freezing inside the heat exchanger.

### The fans' overheating protection

The fans have thermal overload cut-outs, which stop them if the temperature rises too high. The controller also stops the fans if a serious malfunction occurs in the ventilation unit. The protective function resets itself automatically when the temperature drops or the malfunction has been remedied.

### Electric air heater

The electric air heater is equipped with overtemperature protection. If the overtemperature protection trips, you must not continue to use the ventilation unit until the cause of the overtemperature protection tripping has been established and the fault has been rectified.

An automatic overtemperature protection switches off the air heater if a fault situation arises. This protective device automatically resets itself when the air heater has cooled down.

The thermal overload cut out with manual reset can be reset by pressing a button inside the ventilation unit. The acknowledgement buttons are located next to the air heaters. The buttons are marked in the illustrations below. When you press the reset buttons and feel a click, the overtemperature protection (thermal overload cut out) has then been reset.

### Ventilation unit with water-heated air heater

The ventilation unit with water-heated air heater has a temperature sensor that protects the air heater from freezing. The air heater freezing warning alarm appears on the screen if the temperature of the water heated air heater drops too low, but the unit continues to operate normally.

If the air heater's temperature drops further, the controller will stop the ventilation unit to prevent the air heater from freezing. An alarm is then shown on the cooker hood.

When the temperature of the air heater has risen sufficiently, the ventilation unit and panel show a so-called remaining info-alarm, ⓘ. The Info alarm can be reset from "Alarm" on the main menu.

### Cold supply air

The ventilation unit has built-in condensation protection on the ventilation duct. If it is discovered that the supply air is too cold, the ventilation unit stops and an alarm is shown the cooker hood.

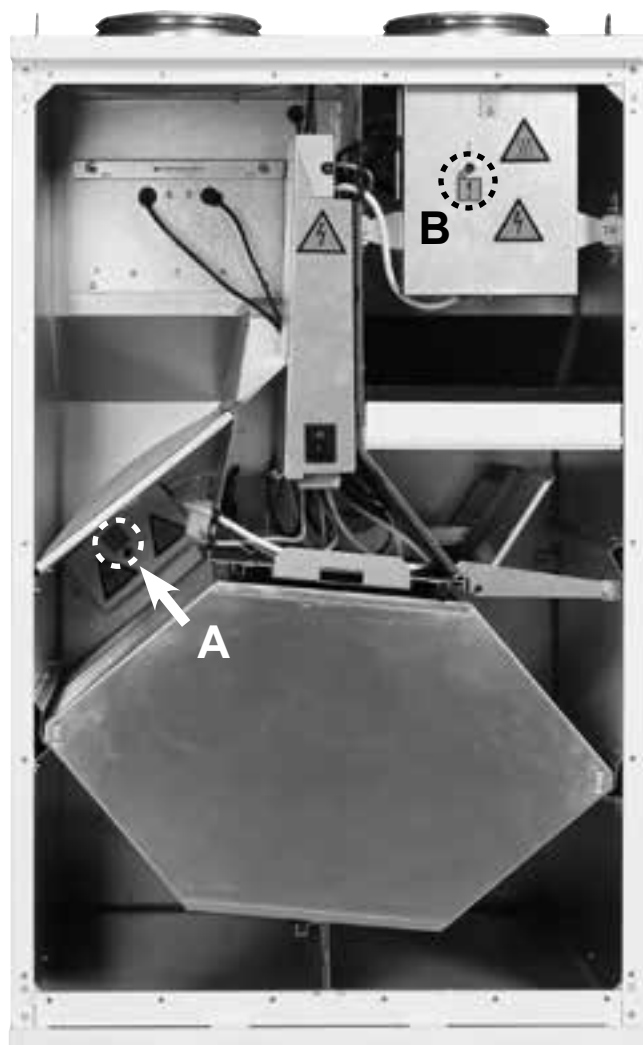

A = Reset button for the overtemperature protection on the preheating air heater

B = Reset button for the overtemperature protection on the reheating air heater

### Temperature sensors

If a sensor fault is detected, the ventilation unit enters restricted mode to prevent damage to the ventilation unit. The functions related to the current sensor in question are deactivated and the ventilation unit works as well as possible. The ventilation unit's function returns to normal once the fault has been corrected.

## 1.7 Automatic energy saving system

An advanced automatic energy saving system, that automatically optimises the operation of the ventilation unit in cold conditions and provides the best possible efficiency up to energy class A+.

This functionality maximizes the ventilation unit's annual energy savings so that the ventilation unit, as seldom as possible, is in defrost mode (as required). The ventilation unit then works constantly with the efficiency that is best for heat recovery. This is achieved using intelligent algorithms in combination with humidity and temperature measurements.

## 2. Installation

### 2.1 Ventilation unit installation site

The temperature in the installation space for the unit should be more than +10 °C, and there should be a drain in the installation space for draining off condensate. The ventilation unit can be installed in a machine room, storage space, etc.

The ventilation unit should not be secured to a wall that borders to a living room or a bedroom due to the risk of noise.

During installation, arrange electric and control cables to make them easily accessible.

The ventilation unit can be mounted on the wall with a wall mounting bracket included in the delivery. The ventilation unit can also be mounted in a ceiling mounting frame or on a base on the floor. The ceiling mounting frame and the base are accessories that are purchased separately.

The unit should be mounted as near as possible to a wall or ceiling. The space between the ventilation unit and the wall should be insulated so that the sound from the unit will not be transmitted out through the rear wall.

#### 2.1.1 Wall mounting

Mount the ventilation unit on a wall by means of a wall mounting bracket which is included in the delivery.

If the wall is composed of vertical studs and wall boards, the wall must be reinforced with horizontal studs that will support the weight of the unit. Swegon also recommends that the wall be insulated with mineral wool or similar insulation for preventing sound from propagating to other rooms.

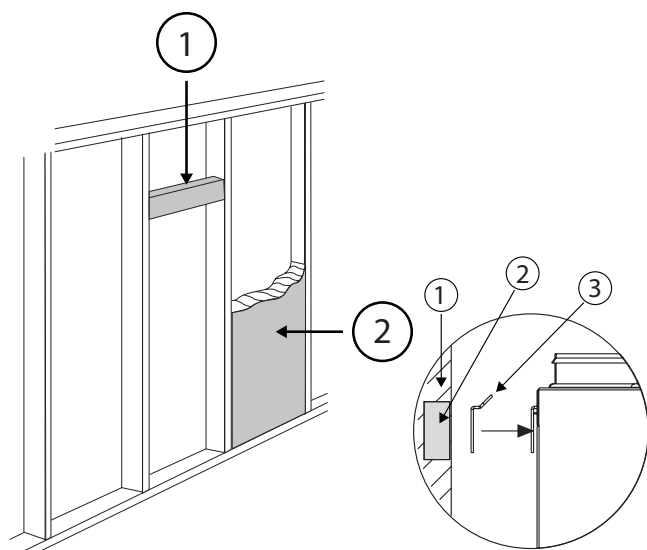

1. Horizontal stud for the ventilation unit's mounting bracket
2. Acoustic insulation

1. Insulated wall
2. Horizontal stud
3. Wall mounting bracket

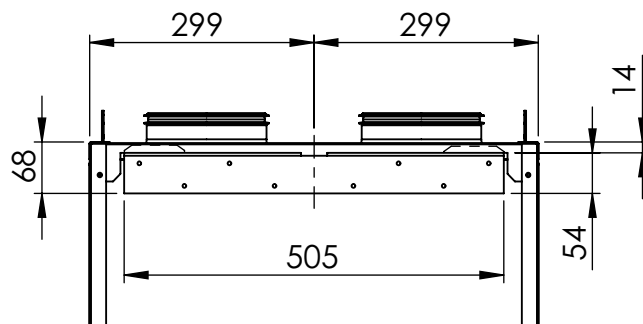

Wall mounting bracket's dimensions

Screw the wall mounting firmly in horizontal position onto the wall where a wall stud will support the weight of the unit.

Screw the adjustment feet in position on the lower edge of the rear wall of the ventilation unit before lifting the unit onto the bracket.

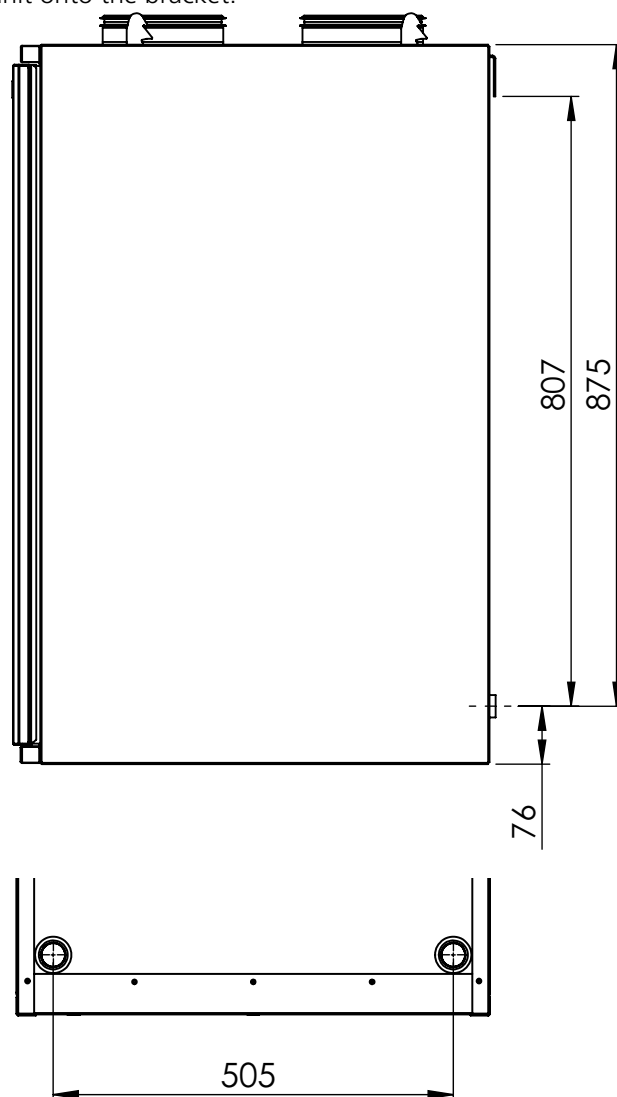

Lift up the ventilation unit onto the wall mounting bracket so that the bracket lugs engage in the corresponding slots at the top on the backside of the ventilation unit. To make it easier to lift the ventilation unit, the inspection cover can be removed and the heat exchanger can be dismantled from the unit. See the "Servicing" Section.

Finally adjust the position of the ventilation unit using

the adjustment feet, so that the unit tilts backwards by a few degrees.

### 2.1.2 Ceiling mounting

The ventilation unit can also be mounted in a ceiling mounting frame (available as an accessory) on the ceiling.

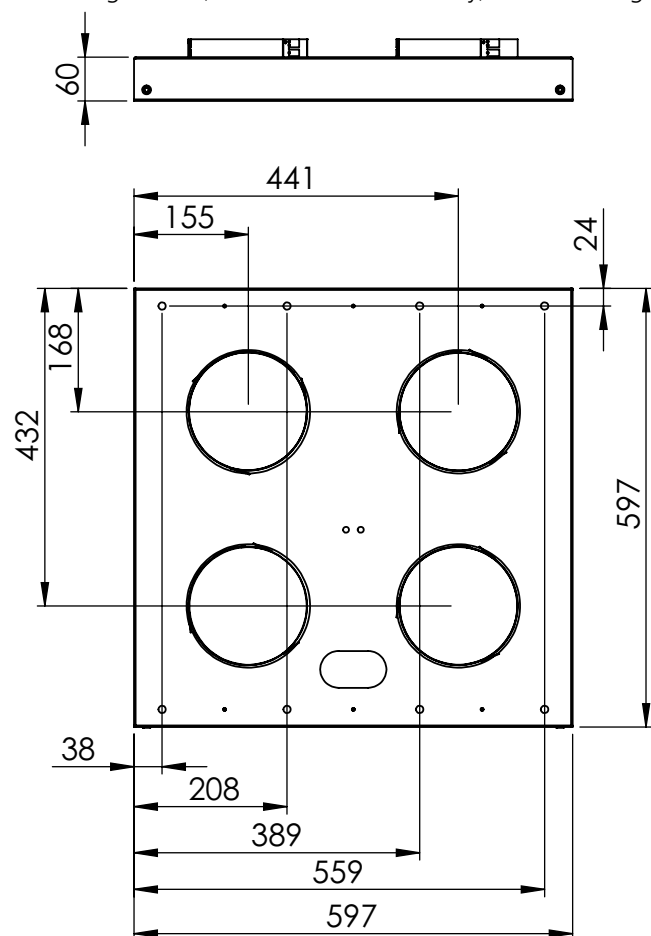

Ceiling mounting frame, dimensions

Fasten the ceiling mounting frame in ceiling anchor pieces with four size M8 threaded rods. Adjust the length of rods so that they will extend no more than 30 mm below the inner surface of the ceiling mounting frame. If they extend further, they will interfere with the upper section of the ventilation unit. Install at least three threaded rods in the corners of the ceiling mounting frame. To avoid a possible collision with the ducts, one of the threaded rods can be located in the hole next to the corner. (Threaded rods and nuts accessories are not included in the delivery.)

Screw in the M8 nuts onto the threaded rods to such a height that the ceiling mounting frame will be horizontal when the top of the frame goes against the nuts. Fit the ceiling mounting frame through the selected holes towards the nuts of the threaded rods and lock the frame into position with nuts from underneath. Adapt the installation height so that the locking screws in the ceiling mounting frame's front section will extend sufficiently far below the ceiling.

**The ceiling mounting frame must not be used as part of a support structure for the ducts**, the duct support must be sufficient even without the support

effect provided by the ceiling mounting frame.

Before you lift the ventilation unit into position, back off the two screws at the front of the ceiling mounting frame so much that the screw heads stick out approx. 2 cm. In addition, route the power supply and data cables through the ceiling mounting frame.

To make it easier to lift the ventilation unit, the inspection cover can be removed and the heat exchanger can be dismantled from the unit. See the "Servicing" Section.

Lift the ventilation unit up against the ceiling mounting frame so that all four locking hooks, which are located on top of the ventilation unit, engage into position. There are two catches on each locking hook. The purpose of the upper one is to secure the ventilation unit to facilitate connection to the ducts and the wiring of the electric cables.

Now lift up the ventilation unit onto the lower hooks when the unit is in the correct position in relation to the ducts and the power cables have been routed into the ventilation unit. When the hooks are locked, the spring-loaded screws of the front section of the ceiling mounting frame extend outward. Finally, lock the ventilation unit into position by tightening the screws.

**Be careful not to press on the screws, because doing so will disengage the ventilation unit. It is not permissible to walk under the ventilation unit during installation.**

!

## Important

!

**If you improperly tighten the ceiling mounting frame, this could turn the frame and the ventilation unit will not have room inside the frame.**

### 2.1.3 Mounting on a base

The ventilation unit can also be mounted on the floor using a base which is available as an accessory.

The ventilation unit's base is mounted horizontally by using the adjuster feet. In order to facilitate lifting the ventilation unit onto the base, the heat exchanger and front cover can first be dismantled from the front of the ventilation unit.

Installation of the condensate hose can be done when the ventilation unit is on the base, by loosening the front edge that is secured with screws. There are openings for the condensate hose on the sides of the base.

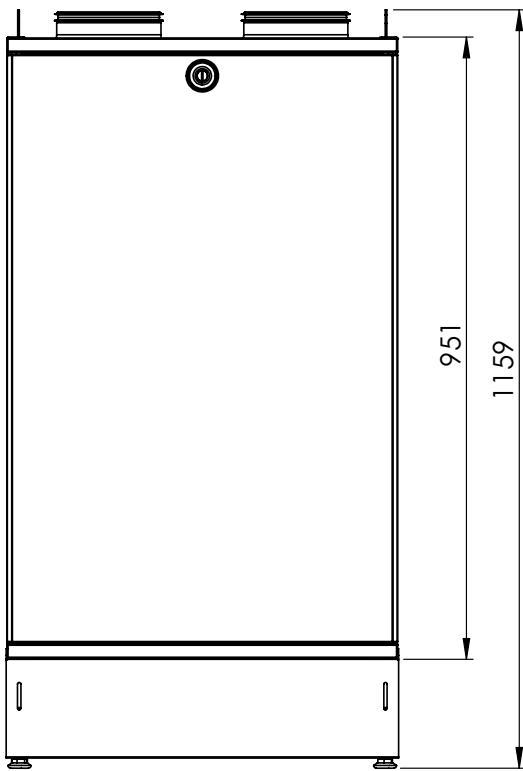

## 2.2 Condensate discharge

Connect the discharge hose to the ventilation unit's condensate discharge connection (3/8" male threads). The condensate must be channelled to a floor drain, the water trap of a sink or the equivalent by means of a tube or a pipe having an inner diameter of at least 12 mm. The tube must not be connected directly to the sewer. The tube must not have a second water trap or be run horizontally. The damming height of the water trap should be at least 100 mm.

Hose to lead off the condensate is included in the delivery of the ventilation unit. The hose has a ready-made loop that serves as a water trap.

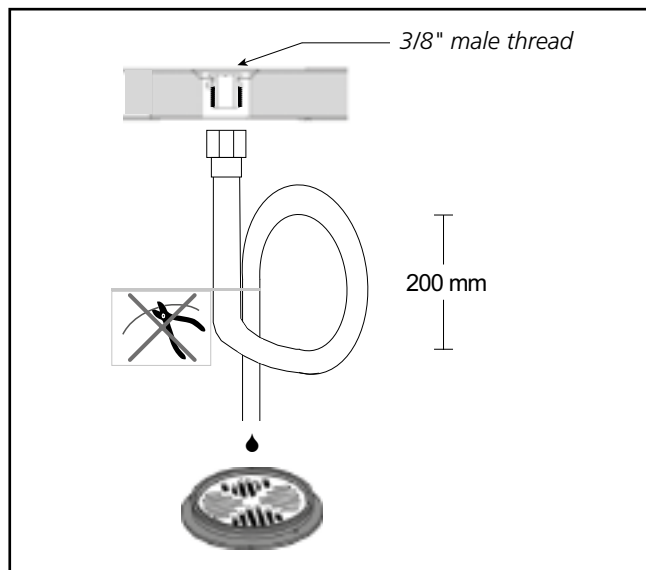

There is a metal water trap available as an accessory (UVLL).

## 2.3 Ducts

Install the ventilation ducts, sound attenuators, supply air diffusers, air intake grilles and exhaust air ducts as shown in the ventilation drawings. To prevent the propagation of sound, do not install the ducts directly against structural building elements.

Insulate the ventilation ducts in order to reduce loss of heat or cooling energy and to prevent water from condensing on surfaces. Any fire protection insulation for the ducts must be designed according to national regulations. **It is of greatest importance to insulate cold ducts without gaps in the insulation, so that moisture cannot condense.**



### Important



**Check whether the ventilation unit has been supplied in the right-hand or left-hand version to make certain that you are connecting the ventilation ducts to the correct duct connection spigots on the unit. Check the ventilation plans to make sure that the duct connections are correctly installed. See also the dimensional drawings in the Section entitled: "Technical data".**

## 2.4 To seal around duct penetration collars

It is important to preserve the tightness of the vapour barrier at the duct penetration collars. We recommend the use of a mounting frame designed for the ventilation unit (accessory, P05PP) for sealing the vapour barrier in the loft ceiling beams.

Cut up the openings with approx. 10 mm smaller diameter than that of the ducts. Secure the mounting frame in the ceiling with screws through the holes on the sides. The plastic film of the vapour barrier should either be stretched and fastened between the mounting frame and the structural element of the building, or be taped tightly against the mounting frame.

The thickness of the insulation and the nature of the surface layer of the ventilation ducts vary depending on insulation material, climate zone and national standards in force. For this reason, Swegon does not offer any recommendations for insulation thickness. Most manufacturers of insulation material offer calculation programs for the calculation of sufficient and correct insulation.

In renovation projects, it is advisable to examine the existing ducts to determine whether they are sufficiently and correctly insulated. Insulating in the right way is necessary for the ventilation unit to operate correctly. **If the ducts are uninsulated, even across a small area, there is a high degree of risk of condensation and indirect damage.**

The supply air duct should be fitted with acoustic insulation along the stretch between the unit duct outlet and the sound attenuator, so that fan sound will not be propagated out into the room.

In general, ventilation ducts should be insulated in the following manner:

- Insulate outdoor air ducts run through warm spaces.
- Exhaust air ducts should always be insulated in accordance with national regulations. See separate project planning instructions (for example Fire resistance classification requirements).
- Insulate supply air ducts in cold spaces.
- Insulate extract air ducts in cold spaces.
- If the air inside the duct is colder than in the surroundings; the insulation should be protected by a vapour barrier.



### Important



**Even small gaps in the insulation impair the sound attenuation and bring about a risk of condensation and consequential damages.**



### Important



**Before commissioning the ventilation system, check that the ventilation unit, filters, condensation drain and ducts are clean and that there are no loose objects inside them. The ventilation ducts should be cleaned regularly and always when the home is renovated.**



### Important



**It is absolutely forbidden to operate the ventilation system during the construction period or if dust-raising work is carried out. Before installing the unit, the ducts should be blanked off with covers to prevent the entry of impurities.**



### Important



**If any further electrical wiring is required, only a qualified electrician shall be allowed to carry out this work. The electric and control cables are located on the upper side of the ventilation unit. Make sure that the electric cable can be connected to a wall outlet without obstruction.**

## 2.5 Electric and control cables

A 1.5 m long cable with earthed plug-in contact is fitted to the ventilation unit for measuring the voltage. The cable extends from the top of the unit. The mains plug serves as the ventilation unit's main switch and it should be connected to an electric socket at an easily accessible spot. For power required, see the Section entitled: "Technical data".

There is an earthing point on the top surface of the ventilation unit body.

On top of the ventilation unit are two modular cables for control of the unit. The maximum connected length of the modular cable in the system is 40 metres. If you lengthen the modular cable within some building element (e.g. in a wall), you should lengthen the cable in a  $\varnothing$  20 mm conduit, anticipating a possible later change of cabling.

When installing the unit, make sure that you provide adequate access to the cable connector, e.g. for servicing and adjusting the unit, if and when the need arises.

In multi-storey buildings, a control panel can be used as a so-called hand-held micro terminal in conjunction with service and installation work.

Any accessories are either connected to the ventilation unit's four-way connector (2 optional functions) or to the external connection modules (3 optional functions). Cables are routed via the lead-through openings in the top of the ventilation unit. The connection of any accessories is described in the section "External connections". Cables to connection modules and accessories are not included in the supply.

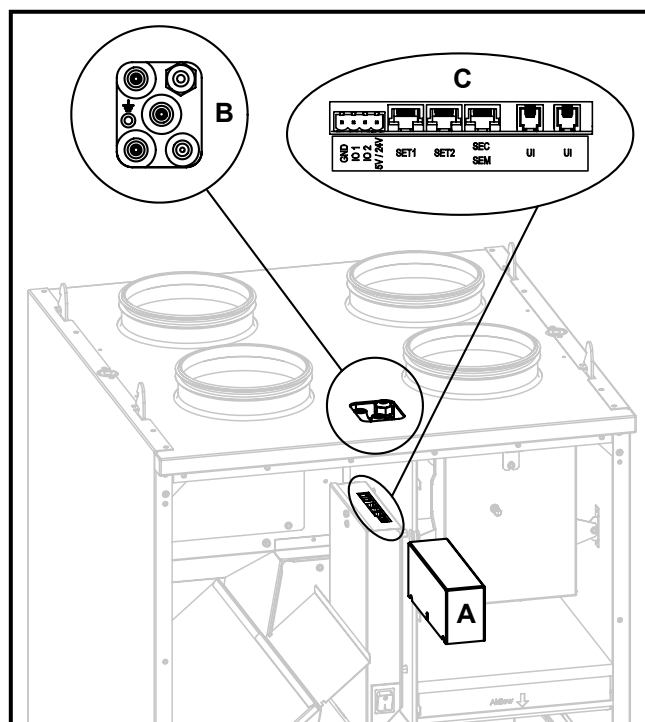

A. Equipment box cover

B. Cable entry for any accessories

C. Terminal blocks for connection of accessories

**NOTE! The cables must be directed, from the terminal blocks, towards the rear of the unit.**

## 2.6 Installation of the Smart control panel

A maximum of two Smart control panels can be connected to the ventilation unit, with different mutual ID numbers. A 20 metre long modular cable is included to connect the control panel. Run the cable to the desired place where the panel will be mounted. A Smart control panel can be mounted up to 40 metres from the unit (using 2 x 20 metre long modular cables).

The front panel on the Smart control panel is released using a screwdriver to push the retaining clips through the holes on either side.



If several control panels are connected in chain, the middle panel's bus termination is moved to the "Open" position. The jumpers do not need to be adjusted if only one control panel is used.



*Bus termination: Terminated*

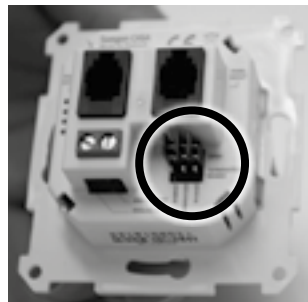

*Bus termination: Open*

The modular cable connected to any outlet socket on the panel.



Finally, refit the front panel.



# 3. Commissioning

**Important**

The functions described in this instruction apply to the ventilation unit and control panels with software version 1.12 and later. In older control panels they only apply to basic functions.

The ventilation system's settings in connection with commissioning and servicing are made from the password-protected "Settings" menu on a Smart control panel. To open the menu, enter code 1234. (The code can be changed). In conjunction with commissioning, you always need to set at least the air flow and carry out any adjustments to the Smart sensor if fitted.

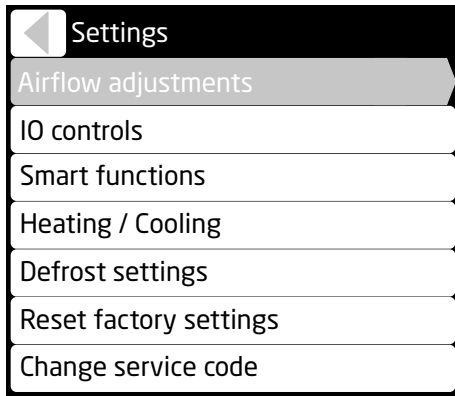

## 3.1 Air flows

Sizing curves for air flows are set out in the section "Technical data". A qualified person should set the ventilation unit's and the ventilation equipment's air flows with the help of measurement equipment so that they correspond with the ventilation plan.

**All basic air flows must be set so that the ventilation unit operates correctly!** Enter the settings in the commissioning protocol.

In new homes, there is still construction moisture and the house initially requires higher ventilation in order to remove the moisture from the building. A great deal of moisture in the home manifest itself in the form of moisture on cold surfaces. We recommend that in new houses to use higher volumes of air at first to remove moisture.

It is recommended in order to improve the efficiency of the ventilation to use an automatic moisture sensor or to actively use the ventilation unit's boost speed, if there is a sauna, pool or equivalent moisture producer in the home.

### 3.1.1 Setting the basic air flows

Before you start to adjust the air flows, ensure that the filters are clean and that there are no foreign objects or debris inside the ventilation unit.

**Important**

Set the air flows in accordance with national regulations when you commission the ventilation system. The system should be commissioned by a qualified person, and the air flows must not be changed on one's own responsibility, since doing so could disrupt the way the ventilation system operates.

Choose commissioning mode when the ventilation unit's fans run at the speed being set and functions that can disrupt the setting, such as anti-freeze protection, are disabled.

Airflow adjustments	
Commissioning mode	<input checked="" type="checkbox"/>
Control type	Fan control
Home (supply)	48%
Home (exhaust)	50%
Away (supply)	35%
Away (exhaust)	38%
Boost (supply)	90%
Boost (exhaust)	92%
Travelling (supply)	35%
Max Smart boost (supply)	82%

Adjust the control functions for the operating modes **Home**, **Away** and **Boost** so that the air flow rates according to the ventilation plan are reached.

Fill in your entered settings in the commissioning report.

### 3.1.2 Travelling

You can reduce ventilation unit's power consumption by using the "Travelling" function, when the home is empty for long periods, among others by reducing the ventilation. Set the supply air flow to "Travelling" mode. The extract air flow is determined automatically based on the basic air flows.

### 3.1.3 Maximum automatic boost

Automatic functions boost the ventilation as required all the way up to the maximum automatic boost. The functions can be limited by reducing the value.

## 3.2 Commissioning external equipment

External equipment can be connected to the ventilation unit's configurable I/O connections (connection instructions can be found in the section "Technical data"). You can connect two optional inputs to the ventilation unit's circuit board and to the SEC/SEM expansion modules, which are available as accessories, you can connect three. The connection of an external duct mounted air

heater is performed to the SET expansion module, according to the instruction supplied with the accessory.

When you connect external equipment to the ventilation unit, the function of I/O connections must be defined in the menu "Setting/I/O-control" (the standard option is shown in the figure).

IO controls	
IO 1	Fireplace - DI
IO 2	Boost - DI
IO 3 (ext.)	Away - DI
IO 4 (ext.)	Emg.Stop_NO - DI
IO 5 (ext.)	DDC control - AI

### 3.2.1 Digital switch input (DI)

Switch input options are:

1. Emg. Stop NC
2. Emg. Stop NO
3. Stop
4. Fireplace
5. Cooker hood
6. Central vacuum
7. Forced boost
8. Away
9. Boost
10. Modbus (not priority)
11. Relay control (not priority)

The priority of the selected inputs is determined according to the previous list, so that a function that is higher on the list has a higher priority than those below.

### 3.2.2 Control inputs (AI)

12. By selecting DDC - AI, the ventilation unit's operating mode can be controlled by a voltage signal.

Operating mode control 0–10 VDC (+/- 0.5 V)

- 0 V = Not DDC control
- 1 V = Travelling
- 2 V = Away
- 5 V = Home
- 8 V = Boost
- 10 V = Stopped

13. Variable control occurs between the voltages 2 V – 5 V – 8 V. The ventilation then switches variably between operating modes Away - Home - Boost. Otherwise, control is performed according to the normal DDC control.
14. Modbus AI\*
15. PA supply air\*
16. PA extract air
17. I/s (supply air)\*
18. I/s (extract air)\*

19. RH AI\*
20. CO<sub>2</sub> AI\*
21. VOC AI\*

\*) See the instruction supplied with the optional equipment.

### 3.2.3 Relay outputs (DO)

The IO connections can be used for relay control (24 VDC). See the connection instructions in the section "Technical data".

As relay outputs you can select:

22. Alarms
23. Duct damper
24. Away
25. Boost
26. Modbus\*
27. DI control The position of the output is controlled by relay control DI.



## Important



**The control card can be damaged if you short-circuit the I/O-connection selected by the relay output.**

### 3.2.4 Control outputs (SEC/SEM – AO4)

The ventilation unit's operating mode can be read as a voltage signal on the AO4 output. If the ventilation unit is controlled variably with Smart functions, the actual value is regulated between the voltages 2 – 5 – 8 V.

Actual value for the fan speed 0-10 VDC

- 0 V = Not DDC control
- 1 V = Travelling
- 2 V = Away
- 5 V = Home
- 8 V = Boost
- 10 V = Stopped

### 3.3 Smart functions

The Smart functions can be activated from the control panel or via external inputs, or they can act as so-called background functions as required. These functions are set as needed from the “Smart functions” menu.

Smart functions	
Smart functions	
Summer mode	
Cooker hood function	
Central vacuum function	
Fireplace function	
Auto Home/Away/Boost	
Auto RH control	
Auto Air Quality control	
Temperature boost	

#### 3.3.1 Shortcuts

From the “Shortcuts” menu you can set which functions are to be visible to the user. When boost is selected, boosting is used on all connected sensors.

Smart functions	
Fireplace function	<input checked="" type="checkbox"/>
Travelling	<input checked="" type="checkbox"/>
Central vacuum function	<input checked="" type="checkbox"/>
Boost	<input checked="" type="checkbox"/>
Summer mode	<input checked="" type="checkbox"/>
Temperature boost	<input type="checkbox"/>
Shut down	<input checked="" type="checkbox"/>

#### 3.3.2 Summer mode

Summer mode bypasses the ventilation unit’s heat exchanger when it needs to cool and the outdoor air is colder than the room air. You then get cool outdoor air in the room.

The heat exchanger takes care of the cool indoor air during hot summer days. The capacity in summer mode can be selected from a quick menu, and the ventilation unit will then automatically determine the cooling.

If you wish to set the function’s settings in more detail, you select “User” mode on the settings menu.

Summer mode	
Mode	User
Fresh air limit	5°C
Fresh air start limit	14°C
Room temperature start limit	Off
Supply air temperature min.	14°C
AC boost	User
Room temperature boost limit	22°C
Hood boost	<input type="checkbox"/>
Use in away mode	<input type="checkbox"/>

*Outdoor air limit* determines at which outdoor air temperature the function is permitted. *Outdoor air start limit* determines the need of cooling.

If you select “Room air temperature limit”, the need of cooling is determined by the room air’s temperature exceeding the *Room temperature start limit*. The supply air limit determines the supply air’s minimum temperature. If you change the value, you must take the risk of condensation on the pipes into consideration.

By changing the value *Boost limit value room temp.* during *AC boost* you can determine at which room temperature the ventilation shall start to variably boost.

Selecting *Hood boost* allows you to operate the damper on a compatible cooker hood to the open position to boost cooling.

Selecting *In use in Away mode* allows you to determine whether ventilation boosting will be permitted in *Away mode*.

#### 3.3.3 Cooker hood function

The cooker hood function balances the ventilation when the cooker fan is used to help prevent excessive negative pressure and improves fume extraction capability of the cooker hood. This function enables you to boost the ventilation if necessary. The function starts automatically when the damper in a Swegon CASA cooker hood is opened or for a cooker hood defined I/O input (IO-control) receives the signal and runs until the damper is closed.

The function is put into service from the *Settings/Smart functions/Cooker hood boost menu*. The settings menu is opened when the function is put into service.

Cooker hood function	
Home state Compensation	20%
Boost state Compensation	0%
Hood boost	85%
Roof fan	<input type="checkbox"/>
In use	<input checked="" type="checkbox"/>
Commissioning mode	<input type="checkbox"/>

Select “Commissioning mode” for air flow settings. This activates the signal to be set and the damper is operated to the open position.

**Compensation (home).** Set the Home mode's compensation value so that the air flows are kept as set out in the ventilation plan.

**Compensation (boost).** Fine tune Boost mode's compensation value if necessary.

**Cooker hood boost.** Adjust the function's boost speed (supply air %), for example, to achieve sufficient discharge velocity or odour extraction.

Choose **Roof fan** when using a cooker hood whose extract air does not pass through the ventilation unit. Compensation is now achieved by slowing the extract air fan and the cooker hood only controls the roof fan.

Also see the section "Commissioning external equipment".

When the outdoor air is very cold, you can lower the supply air fan's speed so that the supply air temperature does not drop too much.

### 3.3.4 Central vacuum function

The central vacuum function helps to balance the ventilation when using a central vacuum cleaner, which prevents excessive negative pressure and improves the cleaning result. A switching signal can be connected to the ventilation unit's signal input (IO-control) so that the function is activated automatically when the central vacuum is started.

The function can also be started from a Smart control panel, the function then runs until the set time has elapsed.

The function's settings can be adjusted from the *Settings/Smart Functions/Central vacuum boost* menu.

Central vacuum function	
Run time	0 min
Compensation	20%

The "Operating time" setting is used to state how long a function started from Smart functions should be enabled (maximum 120 minutes). You can adjust the function's effectiveness using the compensation setting (max 50 %).

### 3.3.5 Fireplace function

The smart fireplace function facilitates lighting the fire and ensures clean combustion. Problems caused by too little draught in an open fireplace usually occur in the autumn, when the temperature difference between the indoor and outdoor air is slight and the chimney is cold. The Fireplace function attempts to give a temporary positive pressure in the home when the fireplace is lit, without changing the fan speeds. After the first phase passes the fireplace function switches to maintenance mode and compensates the need of combustion air. The function can be cancelled from the control panel.

The function can be started from Smart functions or by enabling the I/O input intended for the fireplace function (IO-control). The function runs for the set time and can also be stopped from a Smart control panel.

The function's settings can be adjusted from the *Settings/Smart Functions/Fireplace function* menu.

Fireplace function	
Run time	60 min
Speed difference	20%

Selectable settings for the fireplace function are the function for the desired operating time (max. 60 min) and the desired difference in fan speed (max. 50 %). If problems occur with the chimney draught when lighting the fire, the percentage value can be increased slightly from the default value.

Use of the fireplace function repeatedly in extreme cold can cause freezing in the ventilation unit.

### 3.3.6 Automatic Home/Away/Boost system

The function is available only on models equipped with a carbon dioxide sensor. The automatic control system controls the ventilation strength variably according to the carbon dioxide level in the home.

This function should always be set in conjunction with commissioning.

The function can be activated and set from the *Settings/Smart Functions/Home/Away/Automatic Boost* menu. NOTE! The function is only visible if the sensor has been detected.

Auto Home/Away/Boost	
Mode	In use
A+ now	750 ppm
Home limit	900 ppm
Away limit	600 ppm

The settings menu shows the value "**A+ now**" the current level of carbon dioxide. The function is set by defining the limits values Home and Away. A suitable **Home limit value** can be determined by reading the "**A+ now**" value from the menu when a normal number of people are in the home. Similarly you can determine the **Away limit value** by reading the "**A+ now**" value when the property has been empty for several hours.

### 3.3.7 Automatic humidity system

The function is available only on models equipped with a humidity sensor. The function is put into service from the "Smart-functions" menu. The function boosts the ventilation variably based on the moisture load caused by people, for example, increased moisture load in the home due to showering. If the home's moisture level (RH) remains above 60 % for a long period, we recommend that the ventilation is boosted and that a check is made of the moisture source.

The function can be activated and set from the *Settings/Smart Functions/Auto RH control* menu.

NOTE! The function is only visible if the sensor has been detected. The function is enabled automatically when the sensor is detected.

Auto humidity control	
Mode	
RH now	30 %
Boost limit	5 % + RH
Full boost limit	30 % + RH
Sauna function	<input type="checkbox"/>
Sauna boost	5 %

The value "RH now", the current moisture level, is shown on the settings menu.

The ventilation starts to be boosted variably when the extract air's humidity has risen as much as the **Boost limit value**. The **Full boost limit** value is used to set at which humidity value in the extract air that full boost is reached. Boost increases when the value decreases.

If you put automatic **Sauna limit** into service, the ventilation is boosted with the set value during the sauna. This function prevents any disruptive variations in the fan speeds while the sauna is working.

### 3.3.8 Automatic air quality control

The function is available only on models equipped with automatic air quality. Automatic air quality boosts the ventilation variably according to the indoor air quality.

This function should always be set in conjunction with commissioning.

The function can be activated and set from the *Settings/Smart Functions/Auto air quality control* menu. NOTE! The function is only visible if the sensor has been detected.

Auto Air Quality control	
Mode	In use
AQ now	620 ppm
Boost limit	800 ppm
Full boost limit	1400 ppm
Filter time	2 min

The settings menu shows the value "AQ now" the current air quality level. The function is set by specifying the boost limits where you want the ventilation boost to start and the value at which you want the ventilation unit to reach maximum boost. Appropriate values can be established based on the "AQ now" value shown in the menu.

If it seems that the ventilation system reacts too quickly to changes in the air quality level, you can increase the **filtering time**.

### 3.3.9 Temperature boost

Temperature boost is available if an air heater has been installed in the system, which is available as an accessory, and if you have set room air as the control method on the "Heating/cooling" method. The function boosts the air flow so that the required room temperature is reached.

The function can be activated and set from the *Settings/Smart Functions/Heating boost* menu. The function can be boosted by increasing the boost value.

Temperature boost	
Mode	In use
Heating gain	5 %
Cooling Gain	5 %
Use in away mode	<input type="checkbox"/>

## Important

**Smart measurements: CO<sub>2</sub>, RH and VOC. The absolute values in the measurement result affect how well the control works.**

### 3.4 Heating/cooling

Commissioning and setting of the heating and cooling equipment connected to the ventilation unit are performed from this menu. Detailed instructions are supplied together with accessories. As the factory setting, the ventilation unit normally has internal post heating that is controlled based on the supply air during the heating season (post heating's outdoor air limit). The setting value for the supply air can be decreased in the "Away" and "Travelling" operating modes.

Heating / Cooling	
Adj. method	Supply air
Sensors / controls	
Setpoint	17°C
Setpoint (away)	17°C
Setpoint (travelling)	17°C
Int. post heater	<input checked="" type="checkbox"/>
Ext. post heater	<input type="checkbox"/>
Post heater out limit	8°C
Ext. post cooling	<input type="checkbox"/>
Ext. electric preheater	<input type="checkbox"/>
Ext. liquid coil	<input type="checkbox"/>

The measurement value for the supply air and room air temperature can be fine tuned from the *Temperatures/control functions* menu, if the room temperature that is measured with a separate thermometer deviates from the temperature shown by the ventilation unit.



### Important



**Turning off the internal post heating or lowering the limit value for the outdoor temperature is not recommended, due to the risk of condensation.**

### 3.5 Anti-frost protection

Anti-frost protection on the ventilation unit works automatically. The effect of the anti-frost protection can be increased if necessary by increasing the "Efficiency" value.

Defrost settings	
Efficiency	4
Supply air limit	<input checked="" type="checkbox"/>
Fresh air limit	0°C
Supply air limit (min.)	14°C

Reducing the strength of the ventilation means the "Supply air limit" value prevents cold air from entering the duct system.

### 3.6 Restoring factory settings

Resets all settings made from the control panel, with the exception of the fan speeds.

### 3.7 Changing the service code

This menu is used to change the code to access the setting menu.

◀ Enter code

[ 1 2 3 4 ]

Accept

### 3.8 Use

Issues with reference to the usage of the ventilation system are dealt with in the instructions for use supplied with the unit.

## 4. Service

### 4.1 Service reminder

The service reminder is activated with preset time intervals and the ⓘ symbol is displayed on the control panel's screen. As a factory setting, the service reminder is not in operation. It can be put into operation under the main menu item "Diagnostics"/"Service reminder". The recommended service interval for the ventilation unit is six months.

When servicing has been performed, the service reminder is reset from "Alarm" in the main menu.

### 4.2 To open the ventilation unit

Before you begin any service work, isolate the power supply voltage to the ventilation unit by pulling out its electric plug from the wall socket. Wait a few minutes before you open the inspection door of the ventilation unit so that the fans have time to stop and possible air heaters have time to cool down.

The inspection door can be opened by turning the lock bolt with a screw driver for slotted screw heads. Support the top edge of the door with one hand when you open the lock bolt. Tilt the top edge outwards, towards you, and then lift the door away from its place. The door weighs about 11 kg.

Turn the service switch to the 0-position prior to commencing servicing.

### 4.3 Filter

The filters should be replaced at least every six months. The filters may need to be cleaned or replaced more often in homes where there is considerable dust or if there are many impurities in the outdoor air.

In a new home, there is still moisture from the construction period, and the filters can become soiled more quickly than usual. The first filter change should therefore be made approximately three months after the ventilation unit was commissioned.

The ventilation unit must not be operated without filters. Use only filters recommended by Swegon in the ventilation unit. This is important, as filters with exactly the same appearance and size can have very different pressure losses and filter capacity. If an incorrect filter is used, it is not certain that the ventilation unit will work as designed. Check in the list of components that you have selected correct filters.

### 4.4 Heat exchanger

You should check the condition of the heat exchanger whenever you service the unit.

Pull out the heat exchanger's sealing plate from the ventilation unit. You can now pull out the heat exchanger for inspection. Do not damage the heat exchanger fins.

Make sure that the passages through the heat exchanger rotor are not clogged and clean them e.g. with

running warm water if required. Never use cleaning agents. **The passages of the heat exchanger should be dry before you reinstall the heat exchanger in the unit.**

### 4.5 Fans

The ventilation unit's fans must be checked at least every two years.

You must remove the preheater from the ventilation unit before the supply air fans are loosened. The preheater is secured in the ventilation unit with three screws.

The fan packages are secured with four screws, placed in the corners of the mounting plate. When the screws are loosened, you can pull out the fan package from the ventilation unit. Exercise care not to damage the fan cables.

Clean the fans with a soft brush or cloth if necessary. Be careful not to dislocate the impeller balancing weights. If significant amounts of dirt collect on the fan impeller cleaning should be left to a professional.

The fans are reinstalled by sliding them back into place and tightening the screws in the corners of the mounting plate. The preheater is refitted in position with three screws.

**The ventilation unit's fans must be loosened from their locations and protected, for example, with plastic bags, while the ventilation ducts are cleaned.**

### 4.6 Other servicing

Clean the inner surfaces of the ventilation unit by vacuum cleaning or with a damp cloth, if needed.

Check that dirt has not collected on the surfaces of the air heater/coolers, clean if necessary.

Check that the condensate discharge outlet is not clogged and check its outflow by pouring water on the bottom of the ventilation unit. The condensate discharge connection is located on the rear of the unit under the rotary heat exchanger.

Check that the ventilation unit works normally and that no alarms are shown on the screen or on the cooker hood.



### Important



**The ventilation unit must not be operated without filters! Use only filters recommended by Swegon in the ventilation unit. Find the correct filter in the Section entitled: "Technical data".**

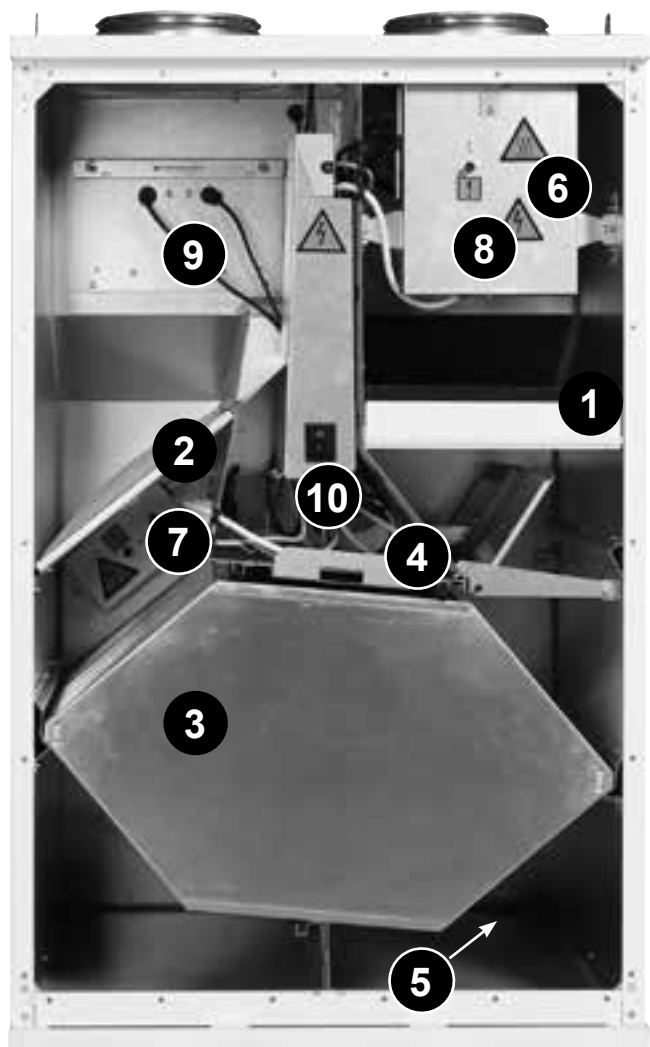



1. *Supply air filter*
2. *Extract air filter*
3. *Heat exchanger*
4. *Heat exchanger's sealing plate*
5. *Condensate discharge*
6. *Air heater, pre-heating*
7. *Air heater, reheating*
8. *Supply air fan's mounting plate (behind the air heater packet)*
9. *Extract air fan's mounting plate*
10. *Service switch*



## 5. Alarms and Troubleshooting

### 5.1 Alarm, cooker hood









If the ventilation unit controlled by a cooker hood malfunctions, all signal lamps on the cooker hood's front glass light three times at one minute intervals. Contact an authorised service company.

### 5.2 Alarm, control panel

Any disruptions to the function of the ventilation unit are indicated by symbols on the upper row of the base display. If there is an active alarm in the system, the screen leaves its standby mode and does not enter standby mode again as long as the alarm is active. The symbol for an active alarm is . The condition that has caused the alarm is shown by the "Alarm" item on the main menu. A so-called info-alarm remains on the screen when the active fault condition ceases.  The Info alarm can be reset from "Alarm" on the main menu.

Important

**Frost protection function**  
Ice can form in the heat exchanger during periods of cold weather if the extract air is humid. A protective function then automatically reduces the speed of the supply air fan. Under such conditions, variations in the fan speed are therefore normal. Under such conditions, small amounts of ice can form inside the ventilation unit.

Status	Alarms	Cause	Action
	T1...T8 sensor fault	Sensor is defective or the cable is loose/not connected.	Contact a service company. The ventilation unit runs in a restricted operating mode.
	Post heater error	Supply air too hot, control/air heater fault or overtemperature protection has tripped.	Contact a service company! Check the function of the air heater for reheating and preheating.
	Preheater error	The temperature of the post heating coil is too high. Control/air heater fault or overtemperature protection has tripped.	Contact a service company! Check the function of the air heater for preheating.
	Freeze risk water-heated air heater	Outdoor temperature below 0 °C and the temperature of the water has dropped below the alarm limit.	Ensure that the circulation pump in the waterborne heating system is running and that the water supply to the ventilation unit's air heater is hot enough.
	Faulty supply air fan	No speed signal from the fan.	Contact a service company.
	Faulty extract air fan	No speed signal from the fan.	Contact a service company.
	Contact fault	Control panel does not communicate with ventilation unit.	Restart the ventilation unit. Contact the service company if the error persists.
	External emergency stop/fire alarm	External emergency stop enabled. The ventilation unit is stopped by the emergency stop function even though the supply air is very cold.	The alarm clears automatically when the external emergency stop or the fire alarm ceases. No info alarm remains afterwards.
	Service reminder	The set service interval has elapsed.	Service the ventilation unit and acknowledge the service reminder.

### 5.3 Troubleshooting

A ventilation system is a unified whole composed of several system components all of which influence how the system operates. A malfunction in ventilation performance could be caused by any component of the ventilation system or by the way the system has been installed. If during the ventilation unit's warranty period (2 years) after a check (see the enclosed check list) there are functional disruptions in the ventilation unit, you can register these using the response form at the address [www.casahelp.fi](http://www.casahelp.fi). There are also instructions, service

videos and frequently asked questions on the same website. You directly access a web page with model specific instructions by reading the QR code on the door of the ventilation unit with a smartphone.

If a problem or a fault occurs on the ventilation system after the warranty period (2 years), contact our network of authorised service companies on [www.swegonhome-solutions.se](http://www.swegonhome-solutions.se), your real estate company's service division or another service company that is fully conversant with ventilation repairs.

## CHECK LIST

### For users of the Swegon CASA ventilation unit

Thank you for your excellent choice of energy efficient ventilation for your home. Swegon designs, manufactures, markets and sells Swegon CASA ventilation units and cooker hoods. Swegon guarantees the functionality of the manufactured units and grants a warranty for them. A ventilation system is a unified whole composed of several system components all of which influence how the system operates. This check list is meant for use by specialists in the building trade and for residents who suspect malfunctions in the ventilation.

### Malfunctions in ventilation performance

A malfunction in ventilation performance could be caused by any component of the ventilation system or by the way the system has been installed. Normal operation of the Swegon CASA ventilation unit is described in the user's instructions supplied with the unit on delivery. If malfunctions occur in the ventilation system, ensure the following with the help of a professional:

- | <input checked="" type="checkbox"/> | <u>Item to check</u>                                                                                                                                                                                                                                                                                                                                                                                                                                                        |
|-------------------------------------|-----------------------------------------------------------------------------------------------------------------------------------------------------------------------------------------------------------------------------------------------------------------------------------------------------------------------------------------------------------------------------------------------------------------------------------------------------------------------------|
| <input type="checkbox"/>            | 1) Make sure that the pipes have been insulated fully according to the instructions and that the insulation reaches all the way up to the ventilation unit so that no uninsulated surface is visible.<br>-> Even a small gap in the insulation could cause among others condensation and acoustic problems.                                                                                                                                                                 |
| <input type="checkbox"/>            | 2) Make sure that the pipes' connections to the ventilation unit are tight and that the unit is installed horizontally.<br>-> If the connections have not been fitted correctly, condensation and acoustic problems could arise.                                                                                                                                                                                                                                            |
| <input type="checkbox"/>            | 3) Make sure that the ventilation unit is equipped with Swegon's original filters ( <a href="http://www.casastore.fi">www.casastore.fi</a> ). This will ensure pressure differentials and the filtration values that conform to the design level, enable the unit to operate correctly and maintain a healthy indoor climate in the home. Make also sure that the filters are clean and replace them when needed. Check also the outdoor air grille and clean it if needed. |
| <input type="checkbox"/>            | 4) Check that there are no unnecessary objects or impurities inside the ventilation unit. At the same time, make sure that the condensate drain in the bottom of the ventilation unit is not clogged by impurities or insects. The condensate drainage function can be checked by pouring a few drops of water on the bottom of the ventilation unit.                                                                                                                       |
| <input type="checkbox"/>            | 5) If the ventilation unit is equipped with electric air heaters, make sure that the excess temperature cutout switches have not tripped. The excess temperature cutout can be manually reset by pressing a button according to the user's instructions.                                                                                                                                                                                                                    |
| <input type="checkbox"/>            | 6) Make sure that the ventilation unit's inspection cover is closed and that it seals tightly along its entire periphery against the unit casing.                                                                                                                                                                                                                                                                                                                           |
| <input type="checkbox"/>            | 7) Check that the air flow rate settings have been set according to the ventilation plan and that the air flow rates to and from the ventilation unit's air heater are in balance (the supply air flow must be 2–10 % less than the extract air flow).                                                                                                                                                                                                                      |
| <input type="checkbox"/>            | 8) Make sure that the fan speeds have been preset for all the operating modes (Away, Home, Boost). If the fan speed settings do not deviate from the factory settings presented in the instructions, there is reason to suspect inadequate commissioning/adjustments.                                                                                                                                                                                                       |
| <input type="checkbox"/>            | 9) Make sure that a correctly recorded and approved measurement record is available.                                                                                                                                                                                                                                                                                                                                                                                        |

If the above-stated checks are not carried out and representatives for Swegon or an authorized service company discover inadequacies in them, the client is responsible for the costs for the service visit, even during the warranty period. If a ventilation unit under warranty is still marred by functional disruptions after the checks, submit a contact request on our web site [www.casahelp.fi](http://www.casahelp.fi). If a problem or a fault occurs on the ventilation system after the warranty period (2 years), contact our network of authorised service companies on [www.swegonhomesolutions.se](http://www.swegonhomesolutions.se), your real estate company's service division or another service company that is fully conversant with ventilation repairs.

## 6. List of components

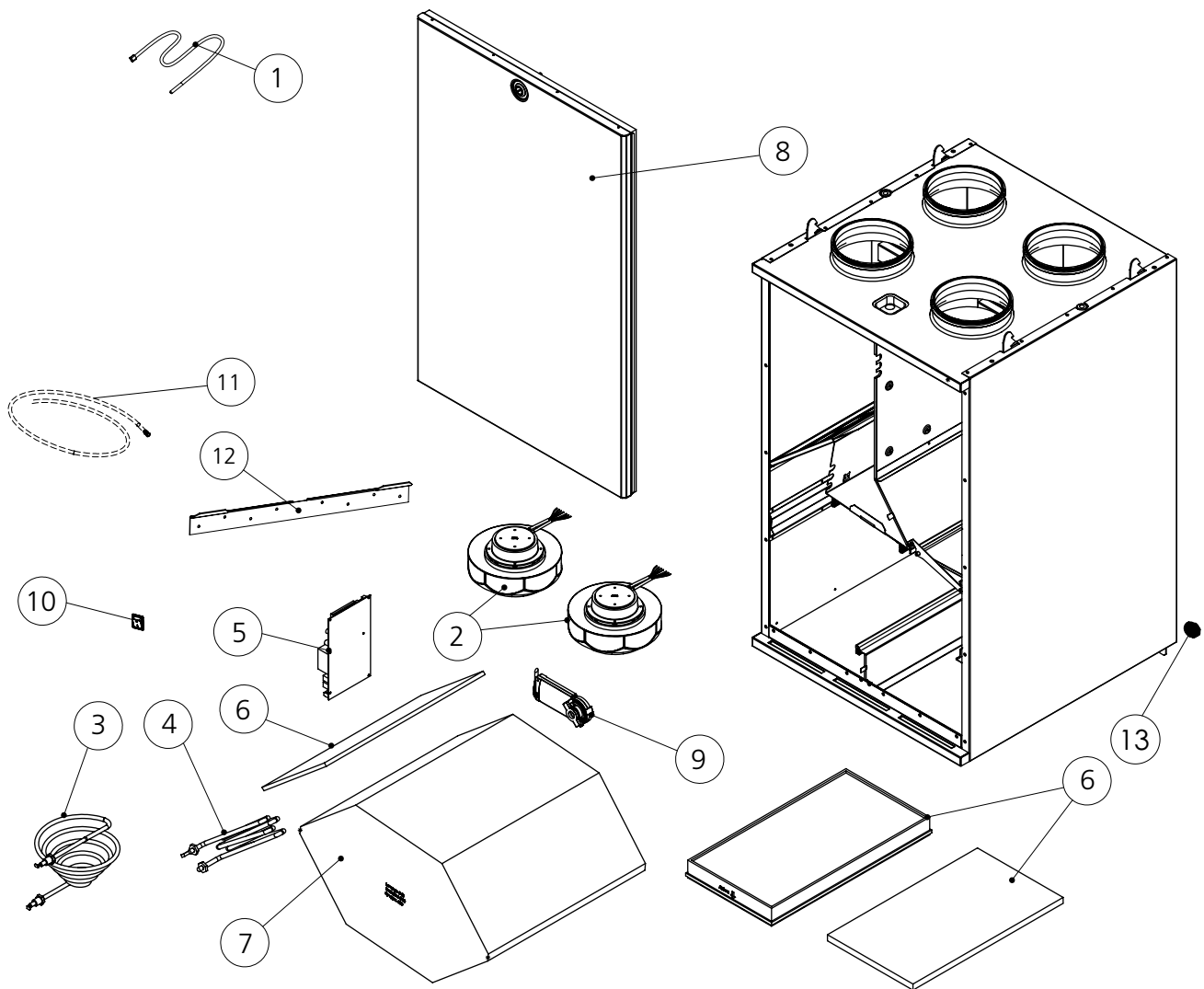

1. Temperature sensor
2. Fan package: FW5
3. Air heater, preheating: 603601
4. Air heater, reheating: 603602
5. EC circuit card: 6030107
6. Set of filters: W05FS
7. Heat exchanger: 61035
8. Cover: DW5RL
9. Damper motor: 60348
10. Service switch: 50319
11. Condensate discharge tube: 502103
12. Wall mounting bracket: W05WMB
13. Anti-vibration mountings (2 pcs.): 60790

### Accessories

- Smart control panel: SC10
- Modular cable: PMK20
- Mounting frame with vapour barrier (R/L): W05PP
- Water trap: UVLL
- Ceiling mounting frame (R/L): W05CMB
- Base: W05FMB
- Filter replacement kit, G3, F7 + heat resistant filter: W05FS

# 7. Technical data

## 7.1 Fan outputs (EN 13141-4)

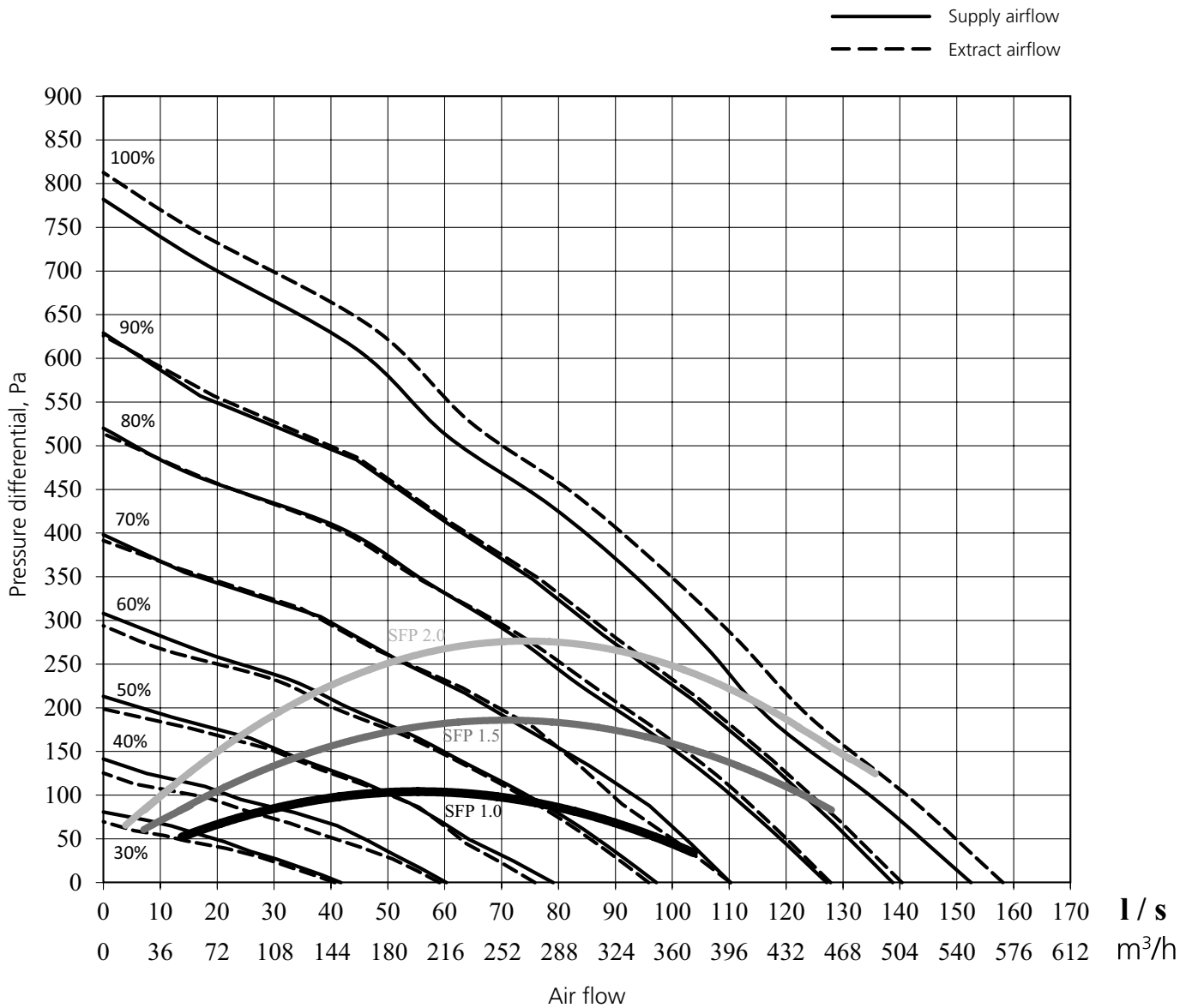

Power consumption

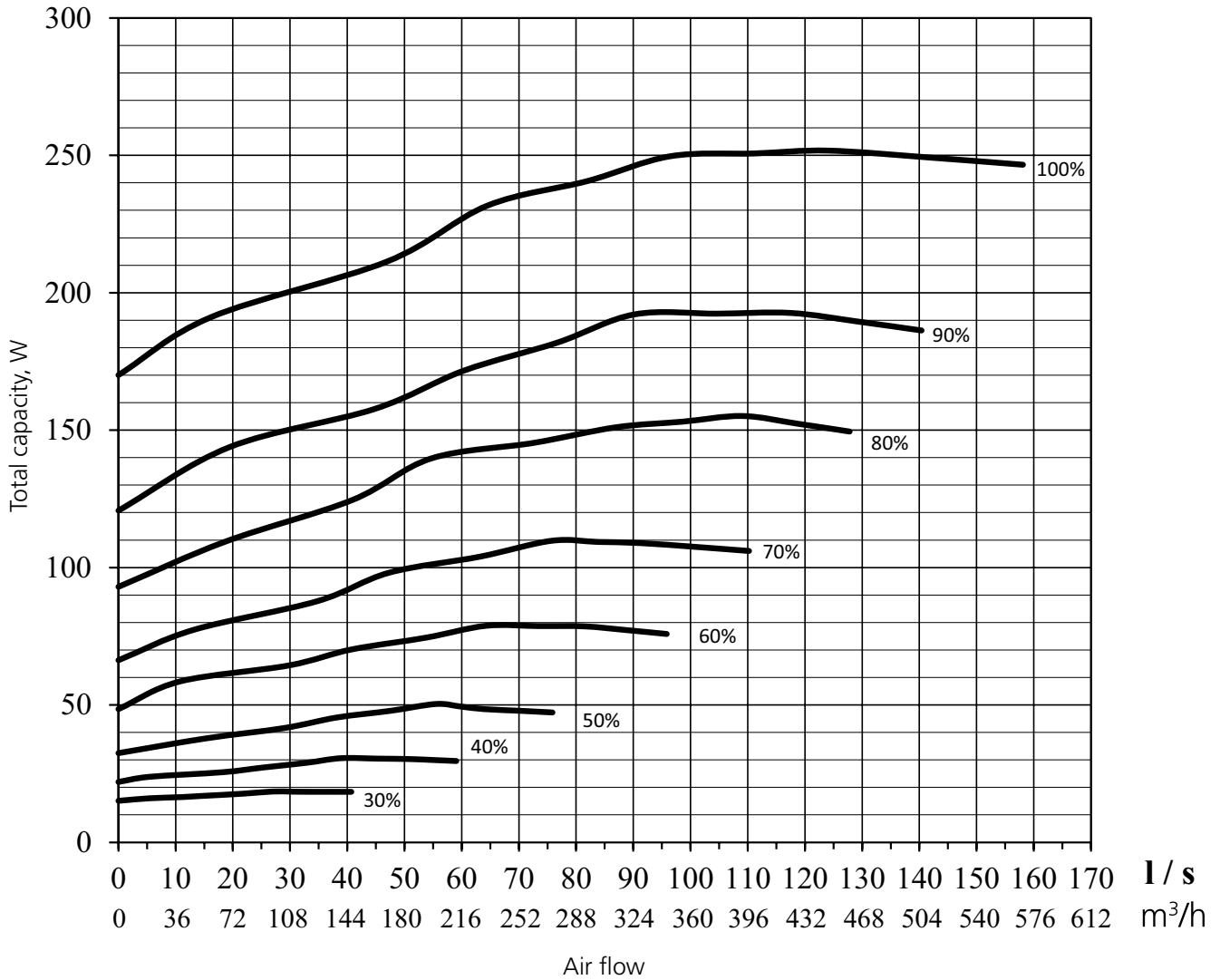

7.2 Outputs of the components

Connection	230 V, 50 Hz, 9,8 A
Fans	238 W
Air heater, pre-heating	1500 W
Air heater, reheating	500 W
Total output	2248 W

## 7.3 Acoustic data

### Sound emitted to supply air duct

Fan setting %	Sound power level broken down into octave bands, $L_{w_{okt}}$ dB								Total assessed sound power level $L_{WA}$ dB(A)
	63 Hz	125 Hz	250 Hz	500 Hz	1000 Hz	2000 Hz	4000 Hz	8000 Hz	
40	63	59	62	52	41	43	38	30	55
50	67	64	67	57	46	48	43	35	60
60	71	68	70	61	50	52	47	39	64
70	76	72	75	66	55	56	51	43	69
80	77	73	76	67	56	58	52	45	70
90	78	75	77	68	57	59	54	46	71
100	80	77	79	70	59	61	56	48	73

### Sound emitted to extract air duct

Fan setting %	Sound power level broken down into octave bands, $L_{w_{okt}}$ dB								Total assessed sound power level $L_{WA}$ dB(A)
	63 Hz	125 Hz	250 Hz	500 Hz	1000 Hz	2000 Hz	4000 Hz	8000 Hz	
40	58	48	48	41	22	20	9	0	42
50	63	53	54	46	27	26	15	0	48
60	67	57	57	50	31	29	18	2	51
70	72	61	62	55	35	34	23	7	56
80	74	63	64	57	37	36	25	9	58
90	75	65	65	58	39	37	26	10	59
100	76	66	67	59	40	38	28	11	61

### Sound emitted to the surroundings

Fan setting %	Sound power level broken down into octave bands, $L_{w_{okt}}$ dB								Total assessed sound power level $L_{WA}$ dB(A)	Sound pressure level 10 m <sup>2</sup> sound absorption $L_p(10)$ , dB(A)*
	63 Hz	125 Hz	250 Hz	500 Hz	1000 Hz	2000 Hz	4000 Hz	8000 Hz		
40	38	39	35	27	16	1	0	0	30	26
50	42	43	39	31	20	5	2	0	34	30
60	48	49	45	37	26	11	8	6	40	36
70	50	50	47	39	28	13	10	8	41	37
80	51	53	49	40	30	15	12	10	43	39
90	53	55	51	42	32	17	14	12	45	41
100	55	56	52	44	33	18	15	13	47	43

\* Equivalent to a normally insulated room. If sound power level  $L_{w_{av}}$  dB (A) values are required, the 4 units (dB) need to be added to the table values.

## 7.4 Electrical wiring diagram

### 7.4.1 Ventilation units

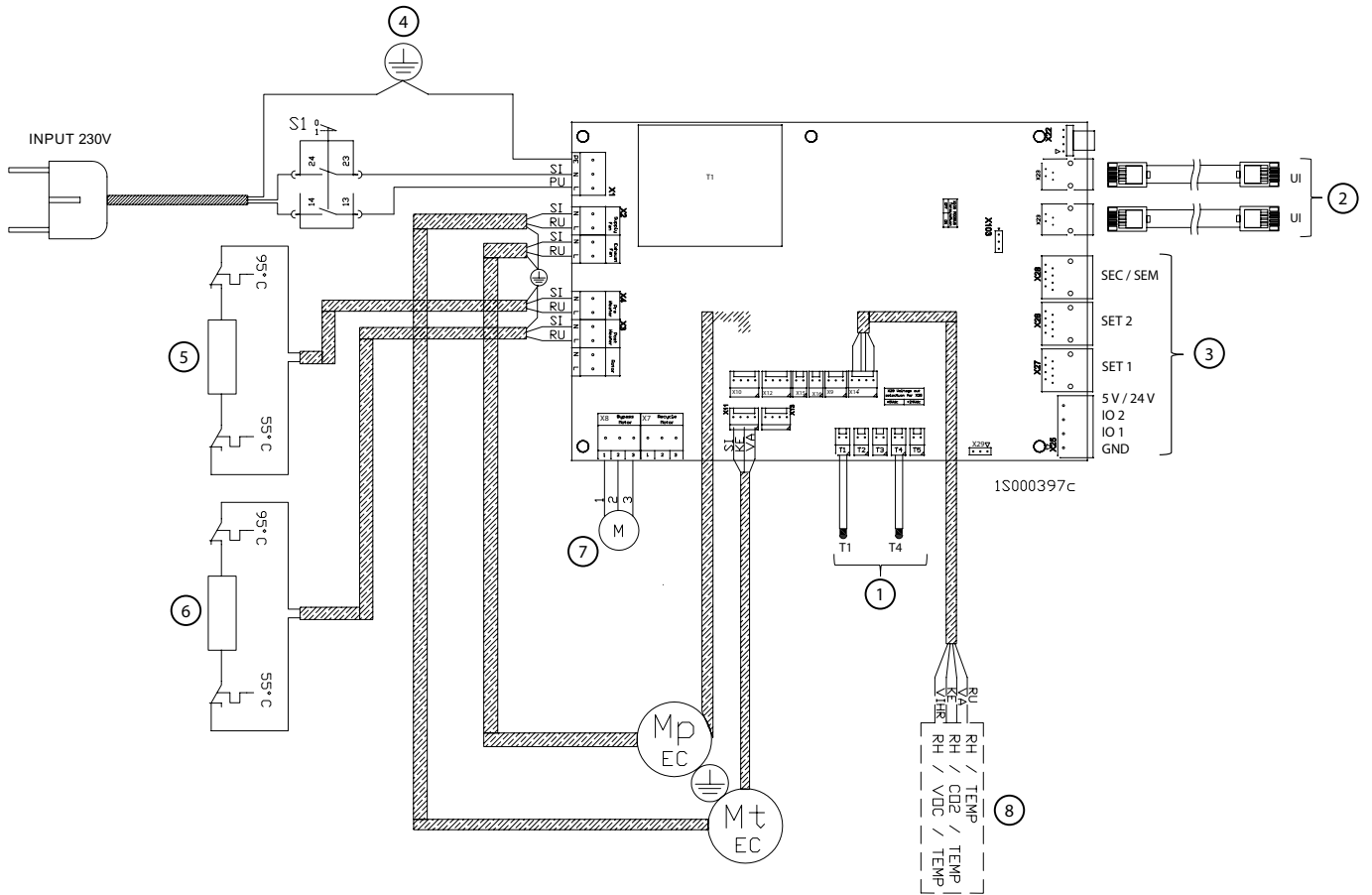

1. Temperature sensor, see the Control diagram
2. Connector for the connection of the Smart control panel or Smart cooker hood, which are sold as accessories.
3. External electrical connections. See the section "Control functions with optional items of equipment".
4. Service switch
5. Air heater, preheat, 1,500 W
6. Air heater, reheat, 500 W (not Econo)
7. Damper motor
8. Smart sensor package
  - RH (standard equipment)
  - RH + CO<sub>2</sub> (accessory)
  - RH + VOC (accessory)



7.4.2 Control functions with accessories

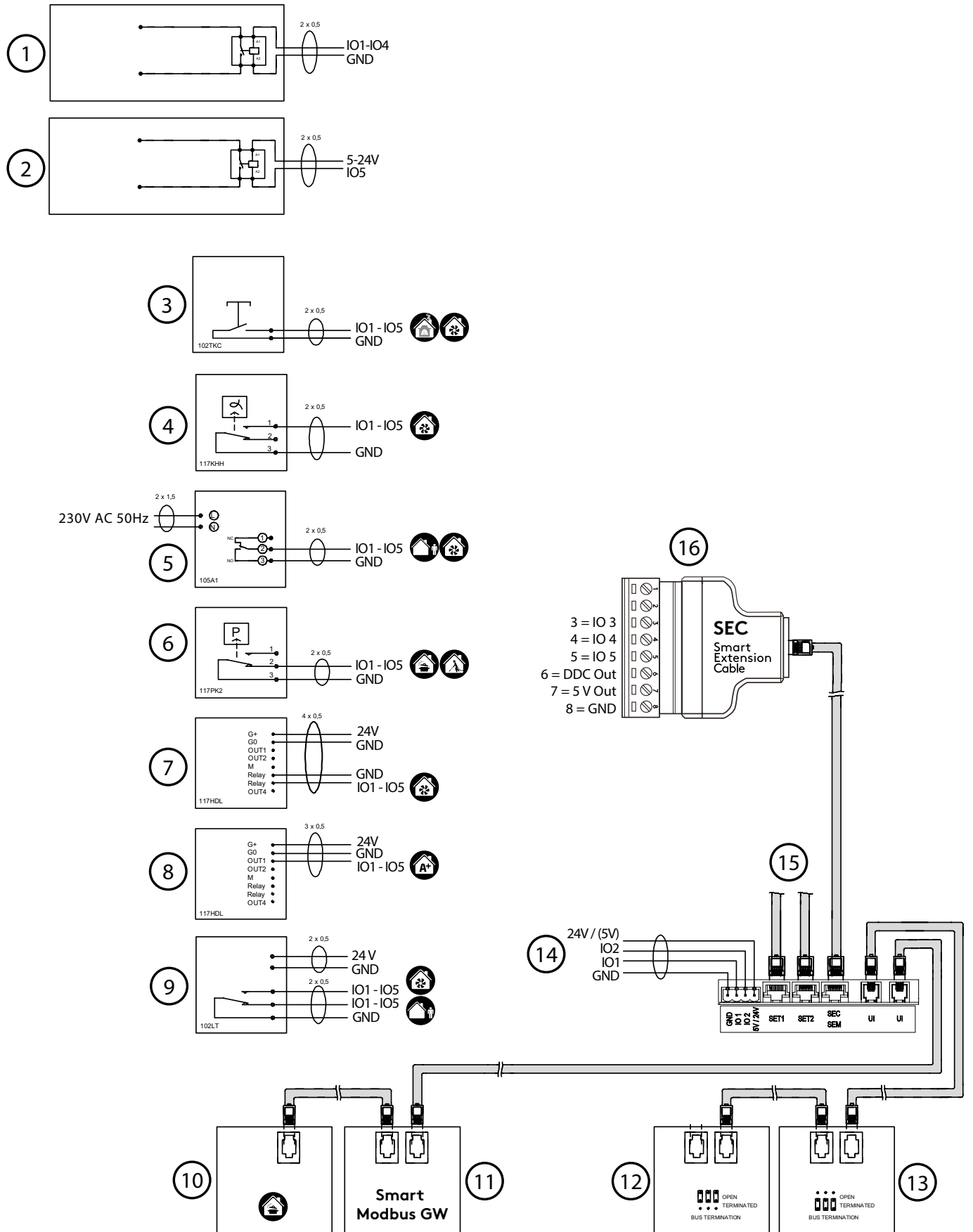

1. External relay control, alarm signal, duct damper, status signal, Modbus
2. External relay control (earthed output), alarm signal, duct damper, status signal, Modbus
3. Fireplace/boost switch, for control of the fireplace function or boosting
4. Humidity sensor, for control of boosting
5. Timer, for control of the Away/Boost mode
6. Pressure switch, for control of the cooker hood/central vacuum
7. CO<sub>2</sub> sensor with relay, for control of boosting
8. CO<sub>2</sub> sensor with relay, for control of Automatic Home/Away/Boost system
9. Presence sensor
10. CASA Smart cooker hood
11. Swegon CASA Smart Modbus gateway
12. Swegon CASA Smart control panel (UP1)
13. Swegon CASA Smart control panel (UP2)
14. Connection points on the ventilation unit: IO1, IO2, 24 V / (5 V), selection from circuit board
15. SET-module, Smart Extension Temperature module, connection card for external duct equipment
16. SEC Smart Extension Cable, connection cable

External equipment can be connected to the ventilation unit's configurable I/O connections. You can connect two optional inputs to the ventilation unit's circuit board and to the SEC/SEM expansion modules, which are available as accessories, you can connect three. The connection of an external duct mounted air heater is performed to the SET expansion module, according to the instruction supplied with the accessory.

When you connect external equipment to the ventilation unit, the function of I/O connections must be defined in the menu "Setting/I/O-control" (the standard option is shown in the figure).

IO controls	
IO 1	Fireplace - DI
IO 2	Boost - DI
IO 3 (ext.)	Away - DI
IO 4 (ext.)	Emg.Stop_NO - DI
IO 5 (ext.)	DDC control - AI

### 7.5 Control diagram

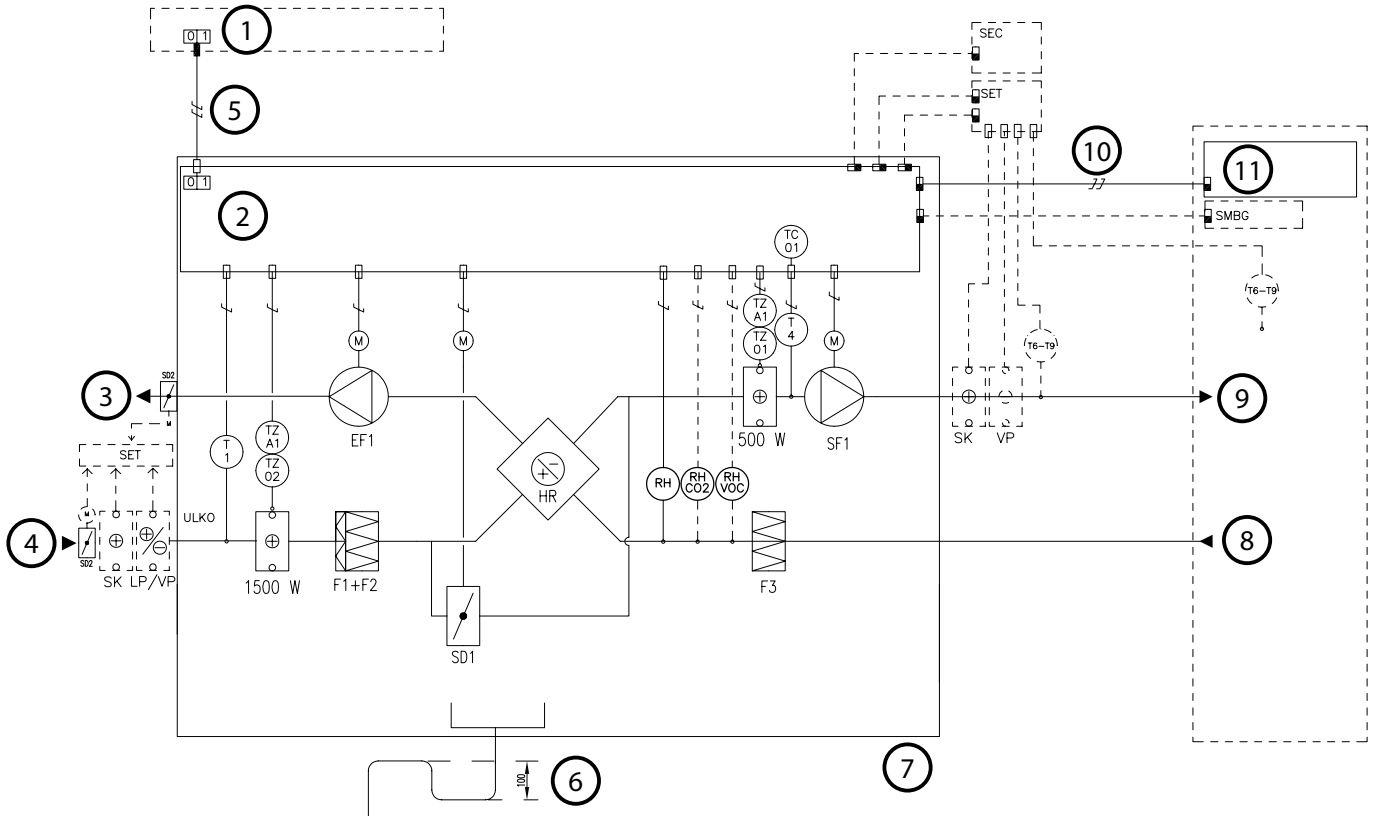

1: Group electrical distribution box | 2: Electrical equipment cubicle | 3: Exhaust air | 4: Outdoor air | 5: Power supply: 230 V, 16 A with plug-in connection | 6: The damming height of the water trap, 100 mm | 7: Supply demarcation of the ventilation unit | 8: General ventilation | 9: Supply air | 10: Modular cables with RJ9-connectors | 11: Control panel

SYMBOL	DESIGNATION	EXPLANATION
TC01	TEMPERATURE CONTROLS	Temperature control for the post heating air heater
T1	TEMPERATURE SENSOR	Temperature sensor, outdoor air
T4	TEMPERATURE SENSOR	Temperature sensor, supply air.
TZ01, TZ02	OVERHEATING PROTECTION	Overheating protection with manual reset
TZA1, TZA2	OVERHEATING PROTECTION	Automatic over temperature protection
SET	CONNECTION UNIT	Connection unit for Smart control signals (accessory)
SEC	EXPANSION CABLE	IO expansion cable, accessory
SMBG	MODBUS MODULE	Modbus expansion module, accessory
F1 + F2	FILTER	Supply air filter
F3	FILTER	Extract air filter
HR	HEAT EXCHANGER	Heat exchanger
SF1	FAN	Supply air fan
EF1	FAN	Extract air fan
SD1	DAMPERS	Bypass damper summer time
SD2	DAMPERS	Shut-off dampers, accessory
SK	AIR HEATER/COOLER	Electric air heater, accessory
LP	AIR HEATER/COOLER	Air heater accessory
VP	AIR HEATER/COOLER	Air cooler, accessory
RH	SENSOR	Humidity sensor
RH + CO2	SENSOR	Humidity/carbon dioxide sensor, accessory
RH + VOC	SENSOR	Humidity/VOC sensor, accessory

**DESCRIPTION OF FUNCTIONS**

**CONTROL FUNCTIONS:**

The ventilation unit can be operated from a separate Smart control panel or a Smart cooker hood, remote controlled via the Modbus field bus or by DCC control. During the heating period, the supply air temperature is controlled from a control panel or via the Modbus field bus. When necessary, the post heating function can also be switched off with settings.

Summer operation: In the summer, outdoor air is guided past the heat exchanger when the controller opens the bypass cover, when a cooling requirement has been established.

- The air heater for reheating is equipped with a manually re-settable TZ01 automatic thermostat (preset limit value: 90 °C) as protection against overheating.
- The air heater is equipped with a TZ02 automatic thermostat with manual reset (preset limit value 90 °C) as protection against overheating.
- The fans have automatic overtemperature protective devices.
- The ventilation unit is equipped with an automatic defrost system that prevents the heat exchanger from freezing by enabling the preheater and if necessary by changing the fan speed.

**IF THE SAFETY EQUIPMENT TRIPS:**

- If an overheating protection with manual reset trips, locate and correct the fault; then press the reset button inside the ventilation unit.
- The automatic overheating protections of the fans will reset themselves when the temperature has dropped below the setting value.

REMOTE OPERATION: Study the ventilation unit manual and the list of parameters for Modbus.

### 7.6 Dimensions

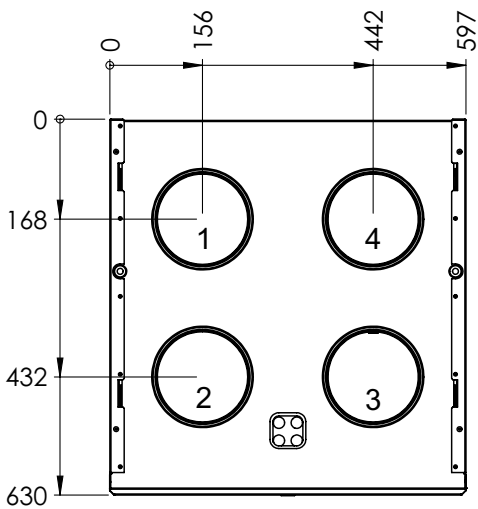
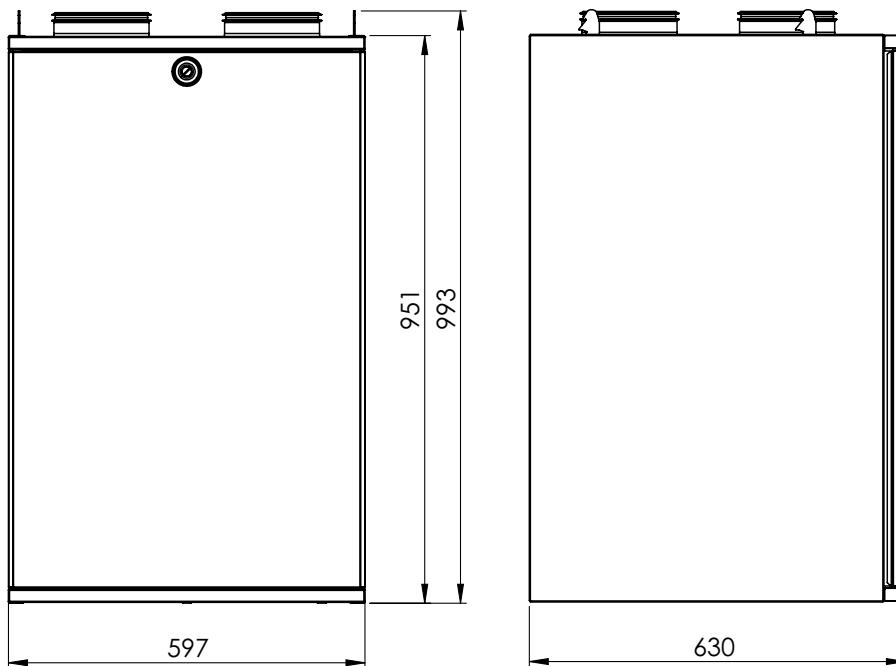
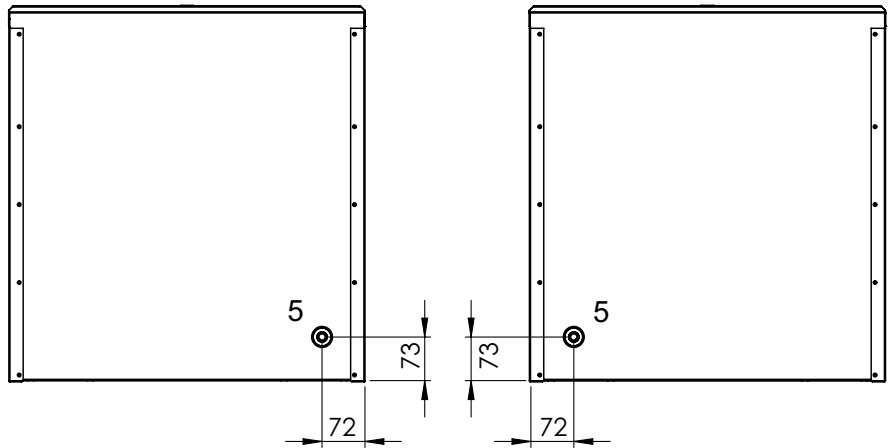

Left-hand model, Model L

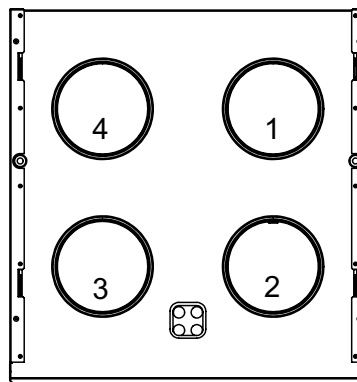

Duct connections			
1	2	3	4
Supply air Ø 160	Extract Ø 160	Outdoor air Ø 160	Exhaust air Ø 160

5. Condensate connection

### 7.7 Weights

Ventilation unit: 85 kg.

**Ceiling mounting frame**

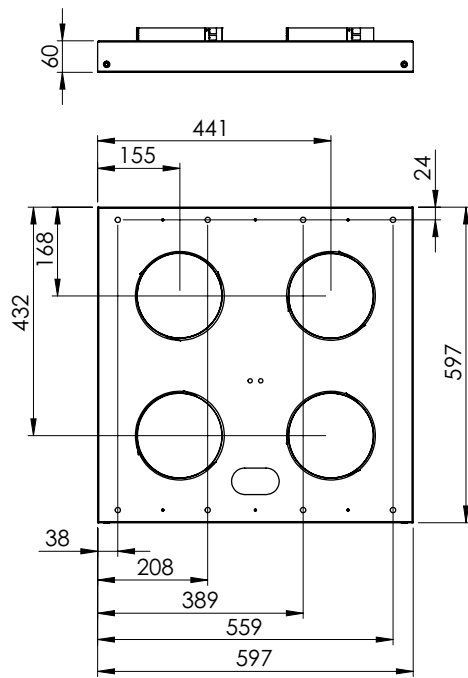

**Wall mounting bracket**

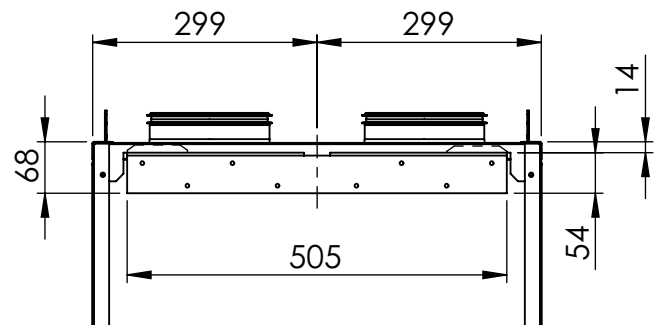

**Base**

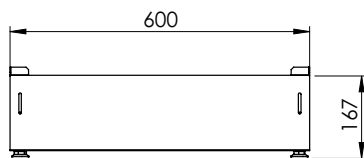

*Einstellbereich 35 mm (15-50 mm)*

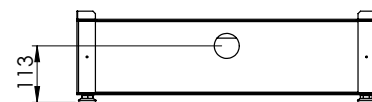
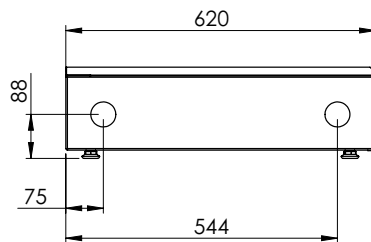

**7.8 Ventilation unit codes**

- W5 Smart R 500 W RH W05VR05S10HAA  
W5 Smart L 500 W RH W05VL05S10HAA
- W5 Smart R 500 W RH CO2 W05VR05S10CAA  
W5 Smart R 500 W RH CO2 W05VL05S10CAA
- Econo model available by using external heating duct coil in the supply air duct. Sensors and actuator are included in the delivery SDHW 160.

## 7.9 Accessories for installation

- Filter replacement kit, G3, F7 + heat resistant filter: W05FS
- Smart control panel: SC10
- Modular cable 20 m: PMK20
- Mounting frame with vapour barrier (R/L): W05PP
- Ceiling mounting frame (R/L): W05CMB
- Base: W05FMB
- Water trap: UVL

### Air cooler for cooling the supply air

- For 160 mm ducts; SDCW 160W
- For 200 mm ducts; SDCW 200W
- For 250 mm ducts; SDCW 250F

### Air heater for heating the supply air

- For 125 mm ducts; SDHW 125
- For 160 mm ducts; SDHW 160

### Air heater in combination with ground source heat pump

- For 200 mm ducts; SDHW 250F

### Electric air heater for outdoor air duct

- For 125 mm duct; SDHE125-1T
- For 160 mm duct; SDHE160-1T
- For 200 mm duct; SDHE200-1T

## 8. Commissioning form

Function	Factory setting	Setting value
<b>Fan speeds</b>		
Away, supply air fan	45 %	
Away, extract air fan	45 %	
Home, supply air fan	60 %	
Home, extract air fan	60 %	
Boost, supply air fan	90 %	
Boost, extract air fan	90 %	
Travelling, supply air fan	45 %	
Maximum automatic boost, supply air fan	90 %	
<b>Smart settings</b>		
A+, Home limit	900 ppm	
A+, Away limit	600 ppm	
Cooker hood function, compensation (home)	20 %	
Cooker hood function, compensation (boost change)	0 %	
Cooker hood function, boost of cooker hood	0 %	
Fahood function, operation of roof fan	Not used	
Central vacuum function, compensation	20 %	

Air flows   NOTE! All the fan modes should be preset.	Project planning values	Setting value
<b>Supply air, total</b>	<b>l/s m<sup>3</sup>/h</b>	<b>l/s m<sup>3</sup>/h</b>
Away		
Home		
Boost		
<b>Extract air, total</b>	<b>l/s m<sup>3</sup>/h</b>	<b>l/s m<sup>3</sup>/h</b>
Away		
Home		
Boost		

**Ventilation unit data** | Write down the data on the ventilation unit identification plate for reference when the need arises to contact a service company.

--

Preset by:	Date:



### Important

**The supply air flow must be 2–10 % lower than the extract air flow.  
Remember to explain the use of the item of optional equipment and how to service it to the user/caretaker!**





**Asennus-, käyttöönotto- ja huolto-ohje**

[https://serviceportal.swegon.com/fi/docs/TM\\_W5\\_FI](https://serviceportal.swegon.com/fi/docs/TM_W5_FI)



**Installations-, drifttagnings- och underhållsanvisning**

[https://serviceportal.swegon.com/fi/docs/TM\\_W5\\_SE](https://serviceportal.swegon.com/fi/docs/TM_W5_SE)



**Installasjons-, igangkjørings- og vedlikeholdsveiledning**

[https://serviceportal.swegon.com/fi/docs/TM\\_W5\\_NO](https://serviceportal.swegon.com/fi/docs/TM_W5_NO)



**Installations-, Inbetriebnahme- und Wartungsanleitung**

[https://serviceportal.swegon.com/fi/docs/TM\\_W5\\_DE](https://serviceportal.swegon.com/fi/docs/TM_W5_DE)



**Installation, commissioning and maintenance instructions**

[https://serviceportal.swegon.com/fi/docs/TM\\_W5\\_EN](https://serviceportal.swegon.com/fi/docs/TM_W5_EN)

Feel good **inside**