



CASA R2 SMART

Installation, commissioning and maintenance instruction

Contents

Technical Guide

for design engineers, installation engineers and service personnel

The section 1 describes the **high lights of the unit**.

All information for **mechanical installation** is found from section 2.

Instructions for **basic commissioning** is found from section 3.

Units external connections to the systems or devices like Modbus, DI, DO, AI, etc. is found from section 4.

Units **functions description and usage** is found from section 5.

Units periodically **maintenance and service** is described in section 6.

If a **malfunction or alarm** occurs the instructions are found from section 7.

All **technical data** is found from section 8.

Important information	3	5.2 Supply air temperature control	19
1. General Description	4	5.2.1 Temperature control settings	19
1.1 Enclosure	4	5.2.2 Temperature measurement	19
1.2 Fans	4	5.2.3 External heating & cooling units	19
1.3 Demand ventilation control	5	5.3 Anti-frost protection	20
1.4 Filter	5	5.4 Restoring factory settings	20
1.5 Heat exchanger	5	5.6 Changing the settings password	20
1.6 Temperature	5	5.7 Use	20
1.7 External connections	5	6. Service	22
1.8 Protective functions	5	6.1 Service reminder	22
2. Installation	6	6.2 To open the ventilation unit	22
2.1 Ventilation unit installation site	6	6.3 Filters	22
2.1.1 Wall mounting	6	6.4 Heat exchanger	22
2.1.2 Cooker hood connection	6	6.5 Fans	22
2.1.3 Installing the unit without the cooker hood	6	6.6 Other servicing	22
2.3 Ducts	6	6.7 Diagnostics	23
2.4 Electric and control cables	7	7. Alarms and Troubleshooting	24
2.5 Installation of the Smart control panel	8	7.1 Alarm indication, cooker hood	24
2.6 Accessories	8	7.2 Alarm indication, control panel	24
2.6.1 Smart sensor package	8	7.3 Troubleshooting	24
3. Basic commissioning	9	7.4 Alarm descriptions	25
3.1 Air flows	9	8. Technical data	26
3.1.1 Setting the basic air flows	9	8.1 List of components	26
3.1.2 Travelling	9	8.2 Airflows (EN 13141-4)	27
3.1.3 Maximum automatic boost	9	8.3 Outputs of the components	27
3.1.4 General notifications	9	8.4 Acoustic data	28
3.2 Cooker hood function	10	8.5 Electrical wiring diagram	29
4. Units external connections	12	8.6 Control diagram	30
4.1 Modbus	12	8.7 Dimensions	31
4.2 Switch inputs (DI)	13	8.8 Weights	32
4.3 Voltage inputs (AI)	13	8.9 Ventilation unit codes	32
4.4 Relay outputs	14	8.10 Accessories for installation	32
4.5 Voltage outputs (AO)	14	Commissioning form	33
4.6 Smart Access	14		
5. Functions and use	16		
5.1 Functions	16		
5.1.1 Shortcuts	16		
5.1.2 Summer night cooling	16		
5.1.3 Cooker hood function	17		
5.1.4 Central vacuum function	17		
5.1.5 Fireplace function	17		
5.1.6 Automatic Home/Away/Boost function	17		
5.1.7 Automatic humidity control	18		
5.1.8 Automatic air quality control	18		
5.1.9 Weekly program	18		

NOTE! The manual's original language is English.



Important information

This document is intended for everyone involved in the installation work for or the use of a Swegon CASA ventilation unit. Read this Instructions for Use before you use the ventilation unit. Save the Instructions for Use for future use. This document is available in our website.

The ventilation unit is not designed to be used by children (below 8 years old) or by persons whose senses, physical or mental capacity or a lack of knowledge and experience limits safe use of the ventilation unit. Such persons may use the ventilation unit if supervised by a person who is responsible for their safety, or according to the instructions.

Installation and commissioning

Only qualified personnel should carry out installation, configuration and commissioning. Only a qualified electrician is allowed to make electrical installations in accordance with national regulations.

The national standards and regulations dealing with unit installation, configuration and commissioning must be followed.

Do not use the ventilation unit until all work that produces large quantities of dust or other impurities has been completed.

The duct connections of the ventilation unit must be covered by lids until it is mounted at its final location.

Make sure that the ventilation unit, filters and ducts are clean and that there are no loose objects in them before you commission the ventilation system.

Electrical work and connections

If you carry out voltage tests, measure the electrical insulation resistance at various points or perform other remedial measures that could damage sensitive electronic equipment, you must first isolate the ventilation unit from the electrical supply grid.

It is recommended that all Smart ventilation units should be equipped with a surge protection device.

It is recommended that all Smart ventilation units should be equipped with a residual current circuit breaker. Comply with local electrical safety regulations when you install electrical equipment.

Drying laundry

A tumble dryer of extract air type or a drying cabinet must not be connected to the system due to the high moisture content in the air it discharges.

Models with water-based air heater

When there is a water-based post heater in the ventilation system the system should be equipped with damper in outdoor air duct so that the air heater cannot freeze during a power failure and unit freezing protection works correctly.

Separate extract air (bypass for cooker hood)

The separate extract air duct runs past the heat exchanger. The separate extract air duct should only be used while cooking and the extract air from the kitchen should be conducted to the ventilation unit's extract air duct. Note that separate extract air flow affects the ventilation unit's annual efficiency.

Condensation

The surface temperature of the ventilation unit can drop down to 12 °C during periods of low outdoor temperature and depending on the moisture content of the air surrounding the unit, moisture may condense on the surface. Condensation should be taken into account when choosing furnishings that are to be installed in the vicinity of the ventilation unit.

Balancing functions

It is recommended to use external preheater when balancing functions are used at temperatures below -10 °C.

To open the ventilation unit for service

Always isolate the ventilation unit's power supply cable before you open the inspection door! Wait a few minutes before you open the inspection door so that the fans are stopped and electrical heaters are cooled.

There are no components inside the electrical box that can be serviced by the user. In case of malfunction, do not restart the ventilation unit before the cause of the fault is identified and fixed.

Filters

The ventilation unit must not be operated without filters! Use only original Swegon filters. Find the correct filter in the section "Technical data".

Warranty conditions

Warranty conditions are included in delivery of the unit as a separate document.

Declaration of conformity

Link to the declaration of conformity:



casahelp.fi

Included in the delivery:

- Air handling unit, R2
- Wall mounting bracket
- Instructions for Use (FI, SE, EN)
- Installation, commissioning and maintenance instruction (SE)

Standard connections:

- Power supply cable with mains plug (2 m)
- Modular cable with RJ9 connector (2 pcs., 1.5 m)
- Free configurable I/O contacts for connection of accessories (2 pcs.)

Accessories:

- Smart user panel
- Modular cable, 20 m, with adapter
- Cooker hood duct plug and insulation plates*
- Front panels (White, Black and Stainless)
- Kitchen door installation kit, magnet
- Upper extension part for unit
- Extension frame for user panel
- SEC: IO-extension cable with Modbus RTU (single point connector)
- SEM: IO-extension module with relay and Modbus RTU (in and out connectors)
- Duct mounted water heating/cooling coils
- Duct mounted electrical heater
- Smart sensors (RH, CO₂, VOC)
- Constant duct pressure kit
- Smart Access Mobile Interface

**) Needed if the unit is installed without cooker hood.*

1. General Description

The most important function of the ventilation system is to ensure clean and fresh indoor air and to remove moisture. The air in the home should be changed at a continuous and sufficient rate to ensure a pleasant indoor climate and avoid damage to building elements caused by dampness.

The Swegon CASA R2 is designed for detached houses, apartment blocks and holiday cottages up to 140 m². Suitable for both new builds and renovation where the unit's unique duct placement is suitable for the replacement of older units. Installation behind a kitchen cabinet door is possible thanks to the unit's flat front.

- Air flow range: 18 - 60 l/s
- Heat exchanger temperature efficiency: up to 83%
- Built-in humidity sensor as standard.
- Constant supply air temperature control
- Energy efficient EC fans with a low noise level
- Available in right or left handed version (supply)
- Can be installed above a stove with the cooker hood installed directly under the unit.
- The unit is built to standard dimensions and can be installed in line with existing cabinet frames and hatches.
- Built-in electric heater for reheating as standard.
- Control System CASA Smart
- Control via control panel, cooker hood (boost), IO's or Modbus
- Meets the Ecodesign directive up to energy class A

1.1 Enclosure

The ventilation unit conforms to enclosure class IP21 when the cover is closed.

1.2 Fans

The Swegon CASA R2 is equipped with energy-efficient fans with speed controlled EC motors. The fans have quick-fit connectors making the fans easily removable from the unit, if required.

The fans can be controlled in four operating modes and steplessly with Smart functions:

- **Boost** = maximum commissioned air flow is used when the ventilation requirement increases, e.g. for cooking, showering or drying laundry.
- **Home** = normal air flow. In normal cases guarantees healthy indoor air quality.
- **Away** = low air flow. Reduces power consumption when no one is in the house.
- **Travelling** = very low air flow and lower supply air temperature. Used when house is empty long period. (Can only be selected from a Smart control panel.)

The unit's weekly timer can change operation modes and temperature setpoint at the preset times. It is always possible to override the weekly timer and change the operation mode from a control panel or a Smart cooker hood.

You can select an air flow boost time of 30, 60 or 120 minutes or continuous boost from a Smart control panel. When the unit is controlled from a cooker hood, the fan's air flow boost time is 60 minutes.

1.3 Demand ventilation control

Ventilation can be controlled by demand with following Smart functions:

- **Stepless Home/Away/Boost Control** = ventilation level is controlled according to the CO₂ level.
- **Humidity Control** = ventilation is boosted steplessly according to the moisture load caused by people.
- **Air Quality Control** = ventilation is boosted steplessly according to VOC level.
- **Smart Balancing Functions** = supply and extract air flow balance is controlled to maintain room pressure level constant. i.e. cooker hood, fireplace or central vacuum cleaner functions.
- **Smart Cooling Boost** = ventilation is boosted according to cooling need.

1.4 Filter

The ventilation unit houses F7 fine filters for the extract and supply air. Filter service is indicated periodically in user panel or CASA Smart cooker hood.

1.5 Heat exchanger

The ventilation unit is equipped with a **efficiency controlled rotary heat exchanger**. Heat exchanger is controlled either to maintain constant supply air temperature or to achieve maximum energy efficiency.

1.6 Temperature

The supply air temperature is regulated by changing the temperature efficiency, with an integrated air heater or with an air cooler, which is sold as an accessory.

In **Eco mode** the ventilation unit works with the best possible temperature efficiency. It must be noted here that the higher the extract air temperature, the greater the direct effect will be on the supply air temperature. The supply air temperature can be adjusted if necessary by warmer supply air.

In **Comfort mode** the supply air temperature is kept even with the help of partially passing heat recovery, i.e. by controlling the temperature efficiency. It must be noted here that the unit is not able to produce supply air that is cooler than the outdoor air.

The control mode for the supply air is selected from the temperature control settings. The default mode is Eco.

The temperature setpoint can be adjusted using the control panel, weekly program, operating mode selection or based on room temperature.

Automatic summer night cooling recognizes the need for cooling. The function lowers the supply air temperature setting and bypasses the heat exchanger for best cooling performance. The unit can't produce cooler supply air than the outside air.

The unit can be equipped with an optional cooling coil, which allows active cooling of the supply air.

1.7 External connections

All connections can be made without opening the electrical box. Plug-in modules are available for external connections. Wide variety of IO functions are available.

The ventilation unit is equipped with In-built Modbus. Modbus cabling can be made easily with external cable (SEC) or module (SEM). Unit can be fully controlled with Modbus and all external IO's can be configured to Modbus usage.

1.8 Protective functions

The heat exchanger freeze protection

The defrosting function guarantees continuous ventilation and maintains units performance even during extreme conditions.

The fan overheating protection

The fan overheat protection stops the fan if the temperature rises too high and is reseted automatically. If protection stops the fans an alarm is generated.

Rotor quard

Rotor quard detects that the rotor is working. Malfunction generates an alarm.

Electric air heaters

The electric heater is equipped with automatic and manual overtemperature protection. Overheat cuts the heating circuit and generates an alarm.

Water-based air heaters

The ventilation unit with water-based air heater/cooler has a temperature sensor that protects the coil from freezing. Protection generates the alarm and starts freezing prevention. If freezing prevention is not enough the unit is stopped and demanded shut-off dampers are closed. Freezing prevention is reseted automatically.

Cold supply air

The ventilation unit has built-in condensation protection. If the supply air is too cold, the ventilation unit stops and an alarm is generated

High temperature

If supply air or units internal temperature is detected dangerously high the unit is stopped and an alarm is generated.

Temperature sensors

If a sensor fault is detected, the ventilation unit runs in restricted mode. The ventilation unit's returns to normal mode once the fault has been corrected.

2. Installation

2.1 Ventilation unit installation site

The temperature in the space where the unit will be installed must be more than +10 °C. The ventilation unit can be installed in a machine room, laundry room, store room, etc.

The ventilation unit can also be installed in the kitchen above the stove and a Swegon CASA Jazz M, Disco or Dance cooker hood can be mounted directly to the unit.

The installation of the ventilation unit is not recommended to a wall that borders to a living room or a bedroom due to the risk of noise.

Ensure easy access to power supply and control cables and accessories.

The ventilation unit should be mounted on the wall with a wall mounting bracket included in the supply.

The unit should be installed on the wall and ceiling so that the ducts remain above the ceiling surface. The space between the unit and the wall/ceiling must be insulated to prevent the transmission of sound coming from the rear wall and top of the unit to the room. Particularly noteworthy; if the unit is not mounted on the ceiling, the sound from top of the unit and from the duct connections must be isolated from the room space.

Important

Before installation, if cooker hood is not installed below the unit, ensure that duct plug and insulation plates (accessory: R000040) are installed in the bottom of the unit.

2.1.1 Wall mounting

The wall mounting bracket is supplied together with the unit.

If the wall is composed of vertical studs and wall boards, the wall must be reinforced with horizontal studs that will support the weight of the unit. Swegon also recommends that the wall be insulated with mineral wool or similar insulation for preventing sound from propagating to other rooms.

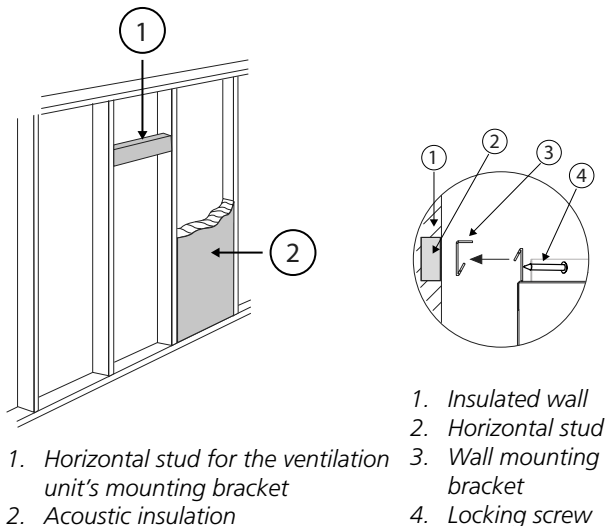

Screw the wall mounting bracket firmly in horizontal position onto the wall where a wall stud will support the weight of the unit. Lift up the ventilation unit onto the wall mounting bracket. Secure installation with locking screw.

The ventilation unit's door and fans can be removed to make it easier to lift the unit. See the "Servicing" Section.

2.1.2 Cooker hood connection

The Swegon CASA Jazz M or Dance cooker hood can be mounted directly below the ventilation unit. Make sure that the distance between cooker hood and stove is according to the local regulations.

Jazz M: Connect the power supply cable to the ventilation unit's pin connector. Connect the modular cable from the ventilation unit to the cooker hood's control outlet. Secure the cooker hood to the ventilation unit with screws included.

Dance: Attach cooker hood cable to the connector at the bottom of the ventilation unit. Secure the cooker hood to the ventilation unit with screws included.

The ventilation unit can be controlled to the cooker hood mode from the cooker hood control panel (does not apply to Dance).

2.1.3 Installing the unit without the cooker hood

If R2 is installed without a cooker hood, a separately sold duct plug and insulation plates must be installed in the bottom of the unit (accessory: R000040).

2.3 Ducts

Important

Check whether the ventilation unit has been supplied in the right-hand or left-hand version to make certain that you are connecting the ventilation ducts to the correct duct connections on the unit.

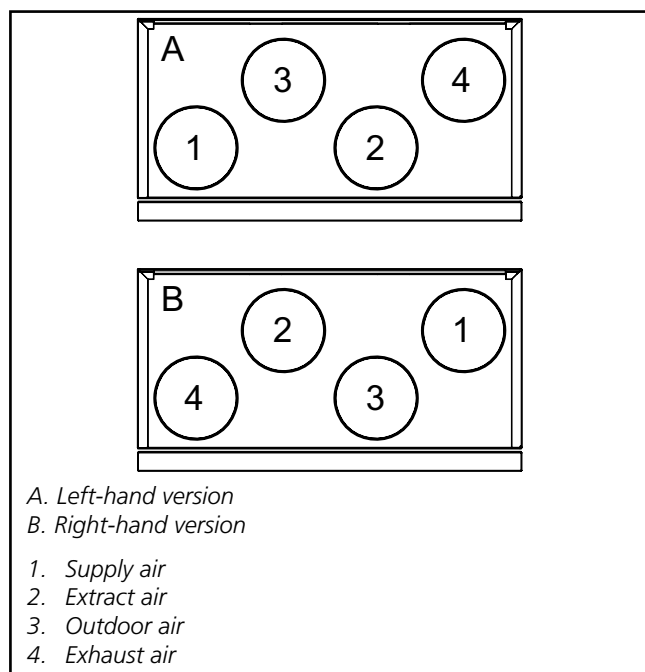

Install the ventilation duct system according to the ventilation drawings. To prevent the propagation of sound, do not install the ducts directly against structural building elements.

Insulate the ventilation ducts in order to reduce heating or cooling, sound and to prevent water from condensing on surfaces. Use fire protection insulation for the ducts according to national regulations. **Cold ducts must be insulated carefully without gaps in the insulation, so that moisture cannot condense.**

The thickness of the insulation must be adequate depending on insulation material, climate zone and according to the local regulations. Most manufacturers of insulation material offer calculation programs for the calculation of sufficient and correct insulation.

The supply air duct should be fitted with acoustic insulation along the stretch between the unit duct outlet and the sound attenuator, so that fan sound will not be propagated out into the room.

In general, ventilation ducts should be insulated in the following manner:

- Insulate outdoor air ducts run through warm spaces.
- Exhaust air ducts should always be insulated in accordance with national regulations.
- Insulate supply air ducts in cold spaces.
- Insulate extract air ducts in cold spaces.
- If the air inside the duct is colder than in the surroundings; the insulation should be protected by a vapour barrier.

It is important to preserve the tightness of the vapour barrier at the duct penetration collars.

2.4 Electric and control cables

An earthed power supply cable with mains plug is fitted to the ventilation. The power cable plug serves as the ventilation unit's main switch and it should be connected to an electric socket at an easily accessible spot.

On top of the ventilation unit are modular cable for control of the unit. The modular cable for the cooker hood is located at the bottom of the ventilation unit. The maximum connected length of the modular cable in the system is 40 metres. If the modular cable is installed within some building element, a \varnothing 20 mm conduit should be used, allowing a possible later change of cabling.

When installing the unit, make sure to provide adequate access to the cable connectors, e.g. for servicing and adjusting the unit.

Any accessories are either connected to the ventilation unit's four-way connector (2 optional functions) or to the external connection modules (3 optional functions). Cables are routed via the lead-through openings in and on top of the ventilation unit. The connection of any accessories is described in the section "External connections". Cables to connection modules and accessories are not included in the delivery.

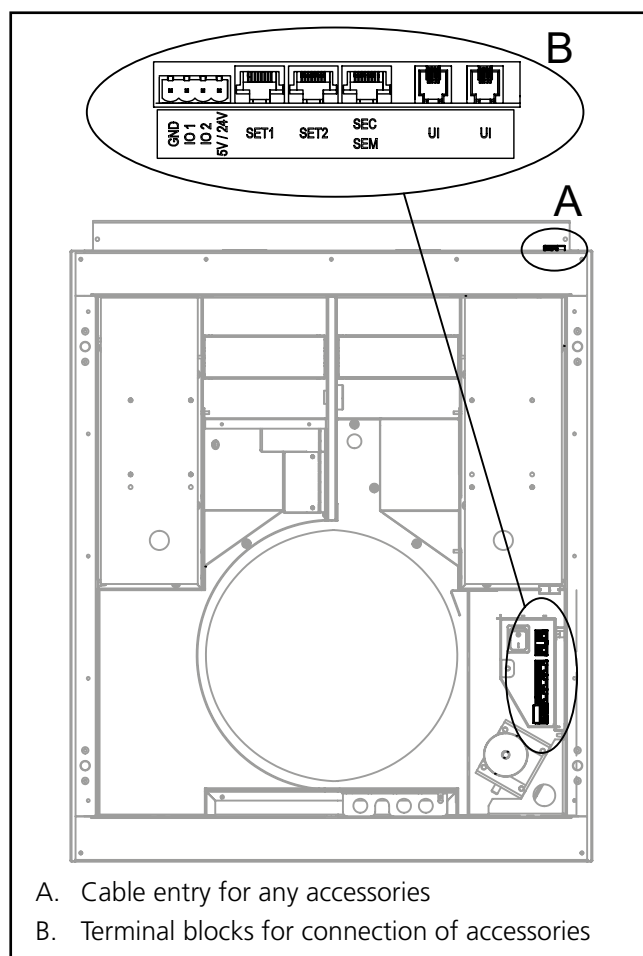

Important

Only a qualified electrician is allowed to make electrical installations in accordance with national regulations.

2.5 Installation of the Smart control panel

A maximum of two Smart control panels can be connected to the ventilation unit. These should be configured with different ID numbers (*Settings/Display/Display ID*). A Smart control panel can be mounted up to 40 metres from the unit (using 2 x 20 metre long modular cables).

The front panel on the Smart control panel is released using a screwdriver to push the retaining clips through the holes on either side.



If several control panels are connected in chain, the middle panel's bus termination is moved to the "Open" position. The jumpers do not need to be adjusted if only one control panel is used.



Bus termination: Terminated

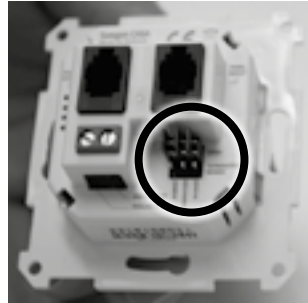

Bus termination: Open

The modular cable can be connected to any outlet socket on the panel.



Finally, refit the front panel.

2.6 Accessories

Installation instructions for accessories are included in the delivery of the each product.

2.6.1 Smart sensor package

Smart Sensor package is a combination sensor:

- Humidity sensor (*SRH*)
- Humidity and carbon dioxide sensor (*SRHCO2*)
- Humidity sensor and VOC sensor (*SRHVOC*).

Units are equipped with a connection cable for the Sensor package. The Sensor package should be installed with provided screw. In Left-hand version one post heater installation screw must be removed and Sensor package should be installed using that hole. In right-hand version there is pre-drilled hole for the Sensor package.

Sensor package placement in the ventilation unit is shown in the following picture.

All sensor combinations of the Sensor package are encapsulated in the same way. If the ventilation unit does have a some Sensor package version pre-installed you can replace the Sensor package. See sensor functions section *Functions and use*.

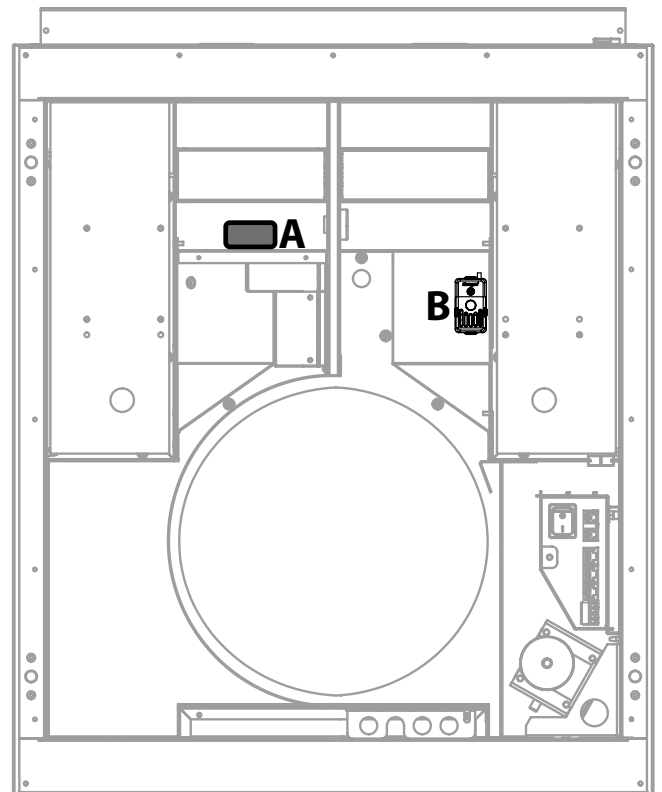

- A. Placement in right-hand version
- B. Placement in left-hand version

3. Basic commissioning

Before commissioning, all tasks in Installation section must be completed. Before the ventilation system can be taken in use, the basic supply and extract air flows must be adjusted. If cooker hood is used, the cooker hood function boost air flow and balancing should be adjusted. If the automatic Home/Away/Boost Smart function is used it must be commissioned, see section 4.

Commissioning is made from the password-protected "Settings" menu on a Smart control panel. To open the menu, enter code 1234. (The code can be changed).

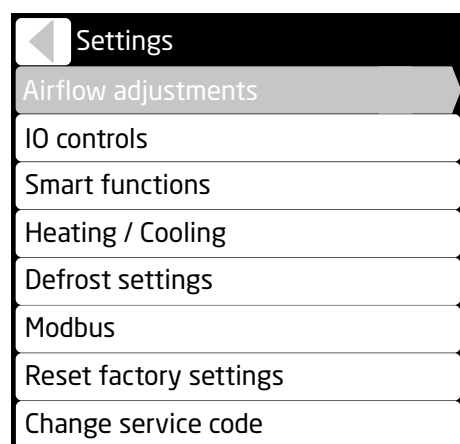

3.1 Air flows

Particular airflows should be found from house ventilation plan. The units air flow curves are found in the section "Technical data". A qualified person should adjust the ventilation air flows with the help of measurement equipment so that they correspond with the ventilation plan.

Air flows for all basic operating modes must be set so that the ventilation unit works correctly! Enter the settings in the commissioning report.

Before you start to adjust the air flows, ensure that the filters are clean and that there are no foreign objects or debris inside the ventilation unit.

3.1.1 Setting the basic air flows

Choose commissioning mode. The ventilation unit's fans run at the selected speed and functions, such as anti-freeze protection and heat exchanger by-pass, are disabled.

Airflow adjustments	
Commissioning mode	<input checked="" type="checkbox"/>
Control type	Fan control
Home (supply)	48%
Home (extract)	50%
Away (supply)	35%
Away (extract)	38%
Boost (supply)	90%
Boost (extract)	92%
Travelling (supply)	35%
Max Smart boost (supply)	82%

Adjust the fan control (%) for the operating modes **Home**, **Away** and **Boost** so that the planned air flow rates are reached.

3.1.2 Travelling

Travelling mode reduces ventilation unit's power consumption. Travelling mode can be used when the home is empty for long periods.

Adjust the supply fan control (%) for the Travelling mode. The extract air flow is defined automatically based on the basic air flows.

3.1.3 Maximum automatic boost

Automatic boost level can be limited if it's disturbing.

Adjust the supply fan control (%) for the max Smart boost. The extract air flow is defined automatically based on the basic air flows.

3.1.4 General notifications

In new homes, there is still construction moisture and the higher ventilation level is needed to remove the moisture.

If there is a sauna, pool or other moisture producer in the home, It is recommended to boost ventilation on demand. This can be managed with Smart humidity control or active use the ventilation unit's boost mode.

!
Important
!

The system should be commissioned by a qualified person. The air flows must not be changed by the user, because it could disrupt the ventilation system operation.

Air flows must be adjusted according to the local regulations.

Never adjust the air flows under the units specified minimum.

3.2 Cooker hood function

The cooker hood function balances the air flows when the cooker hood is used. This will help to prevent house negative pressure and improves fume extraction capability. The ventilation boost level during the function can be defined. The function starts automatically when the damper in a Swegon CASA cooker hood is opened or when a cooker hood defined IO is active. (Does not apply to Dance.)

The function and the air flows can be commissioned from the menu *Settings/(1234)/Smart functions/Cooker hood boost*.

Enable the function by selecting it In use.

Cooker hood function	
Home state Compensation	10%
Boost state Compensation	0%
Hood boost	85%
Roof fan	<input type="checkbox"/>
In use	<input checked="" type="checkbox"/>
Commissioning mode	<input type="checkbox"/>

Choose commissioning mode. The ventilation unit's fans run at the selected speed and functions, such as anti-freeze protection and heat exchanger by-pass, are disabled.

Open the cooker hood damper.

Define the cooker hood air flows in order to adjust function values.

Home state Compensation. Adjust the Home mode compensation value so that the supply and extract + cooker hood air flows are in balance. Compensation increases supply air flow. (If roof fan compensation is selected, the extract air flow is first reduced).

Boost state Compensation. Fine tune Boost mode compensation value if necessary.

Hood boost adjusts the ventilation level during the function, for example, to achieve sufficient discharge velocity or odour extraction.

Choose **Roof fan** when using a cooker hood which is connected to the roof fan. Compensation is achieved by slowing the extract air fan.

4. Units external connections

This section contains information to connect ventilation unit to external devices or system. The unit has in build Modbus RTU interface to complete control. The units operating modes and functions can be controlled with switch inputs (DI) or with voltage (0...10 V). The unit state can be monitored from relay outputs or voltage output (0...10 V).

4.1 Modbus

Unit has in build Modbus RTU interface (slave) and it's available in a SEC* or SEM* module. SEC IO-extension cable Modbus interface is designed for single point connection. SEM IO-extension module Modbus interface is designed for easy connection to large network with in and out connectors for A, B and for two shield or ground connectors.

Installation

Install Modbus network cabling as described in external connections diagram.

NOTE! Install bus termination to chains last unit (in SEM use bus terminated jumper, JP1).

NOTE! Shielded cable must be grounded only from one point (master). SEM has two internally connected connectors for shield/ground chaining.

Settings

Modbus settings can be changed in *Settings/(1234)/Modbus* menu.

◀ Modbus	
Address	1
Baud	38 400
Data bits	8
Stop bits	1
Parity	None
Smart Access	<input type="checkbox"/>

If Smart Access is connected to the SEC/SEM module select Smart Access for correct settings. Normally Smart Access cable should be connected inside electrical box.

Register access

Modbus registers defined in registers list are direct accessible without password. All defined registers are PLC addresses (base 1). Most commonly used registers are listed below.

Holding control registers		
4x5001	Operating mode	0 = Stop 1 = Away 2 = Home 3 = Boost 4 = Travelling
4x5018	Emergency stop	0 = Disabled 1 = Active 2 = Over pressurising
4x5101	Temperature setpoint	°C
4x5406	Reset all alarms	1 = Reset

Input registers		
3x6201	Fresh air temperature	0,1 °C
3x6203	Supply air temperature	0,1 °C
3x6204	Extract air temperature	0,1 °C
3x6213	CO2	PPM
3x6214	RH	%
3x6217	VOC	PPM eqv.
3x6205	Supply fan RPM	1/s
3x6206	Extract fan RPM	1/s
3x6301	Unit state	0 = Ext. stop 1 = User stop 2 = Start 3 = Normal 4 = Commissioning
3x6302	Operating mode	0 = Stop 1 = Away 2 = Home 3 = Boost 4 = Travelling
3x6136	Combined alarm	See full list
3x6137	Combined info	See full list

Full register list:
www.swegonhomesolutions.com



*) Accessory

4.2 Switch inputs (DI)

Unit operating modes and functions can be controlled with switch (digital) inputs. All inputs are configurable to any operation, and input polarity (NC/NO) can be selected. The unit has two inputs (IO1 and IO2). SEC/SEM* modules has three inputs more (IO3, IO4 and IO5).

Installation

Install switch devices to selected inputs (IO1-IO5) and ground.

Settings

IO settings can be changed in *Settings/(1234)/IO controls* menu. Configure input type to *switch input*. Select active state according to application. Closed selection will active function when input is connected to ground (NO).

Operations

Select required switch function:

1. **Emergency stop**
Emergency stop when input active.
2. **Stop**
Unit stopped when input active.
3. **Fireplace**
Fireplace function activated by input pulse, function time defined in Smart settings.
4. **Hood**
Cooker hood function active when input active.
5. **Central vacuum (CVC)**
Central vacuum cleaner function active when input active.
6. **Boost force**
Boost mode active when input active, overrides Away mode.
7. **Away**
Away mode active when input active.
8. **Boost**
Boost mode active when input active.
9. **Modbus (not priority)**
Input status can be read from Modbus.
10. **Relay control (not priority)**
Input status can control relay output.
11. **Emergency stop resettable**
Emergency stop activation. Emergency stop is reset from user panel.
12. **External alarm.**
Alarm indication for external devices.

4.3 Voltage inputs (AI)

Unit operating modes can be controlled with analog voltage (0...10V) and different sensors can be connected to voltage inputs. The unit has two inputs (IO1 and IO2). SEC/SEM* modules has three inputs more (IO3, IO4 and IO5).

Installation

Install control or sensor cable to selected inputs (IO1-IO5) and ground.

Settings

IO settings can be changed in *Settings/(1234)/IO controls* menu. Configure input type to *voltage input*.

Operations

Select required analog input function:

1. **Operating mode**
Operating mode control 0...10 VDC (+/- 0.5 V)
0 V = Control disabled
1 V = Travelling
2 V = Away
5 V = Home
8 V = Boost
10 V = Stopped
2. **Operating mode, stepless**
Operating mode control 0...10 VDC (+/- 0.5 V)
0 V = Control disabled
1 V = Travelling
2 V = Away
Stepless control between Away and Home
5 V = Home
Stepless control between Home and Boost
8 V = Boost
10 V = Stopped
3. **Modbus AI**
Analog voltage can be read from Modbus.
4. **PA supply air****
5. **PA extract air****
6. **I/s (supply air)****
7. **I/s (extract air)****
8. **RH AI****
9. **CO₂ AI****
10. **VOC AI****

*) Accessory

***) Instructions are supplied with accessory

4.4 Relay outputs

External devices or systems can be controlled with relay control outputs (+ 24 VDC). The units two inputs (IO1 and IO2) can control external relays. SEM* module has one inbuilt relay (IO3) and two outputs for external relays (IO4 and IO5). IO5 is grounding digital output for direct connection to automation system.

Installation

Install external relay or system according to drawings.

NOTE! The control card can be damaged if you short-circuit the IO connection selected by the relay output.

Settings

Relay settings can be changed in *Settings/(1234)/IO controls* menu. Configure input type to *relay output*. Select active state according to application. *Closed* selection will close/activate the relay output when function is active (NO).

Operations

Select required relay function:

1. **Damper**
Output is active when unit is running.
2. **Away**
Output is active when unit is in Away mode.
3. **Boost**
Output is active when unit is in Boost mode.
4. **Modbus**
Output is controlled with Modbus.
5. **DI control**
Output is controlled with digital input. Switch input must be defined as relay control. Relay output minimum and/or maximum active time can be defined from IO controls menu.
6. **Manual on**
Output is always on.
7. **Travelling**
Output is active when unit is in Travelling mode.
8. **Service.**
Output is active when service reminder is active.
9. **Critical alarm**
Output is active when critical alarm is active. Unit is operating in restricted mode.
10. **Alarm**
Output is active when any alarm is active.

4.5 Voltage outputs (AO)

External devices or systems can be controlled with analog output (0...10 V). SEM/SEC* module has one analog output (AO4).

Installation

Install device or control cable to AO4 and ground.

Settings

IO settings can be changed in *Settings/(1234)/IO controls/AO4* menu.

Operations

Select required output function:

1. **Operating mode**
Operating mode output 0...10 VDC
 - 0 V = NA
 - 1 V = Travelling
 - 2 V = Away
 - 5 V = Home
 - 8 V = Boost
 - 10 V = Stopped
2. **Operating mode, stepless**
Operating mode output 0...10 VDC
 - 0 V = Control disabled
 - 1 V = Travelling
 - 2 V = Away
 - Stepless output between Away and Home*
 - 5 V = Home
 - Stepless output between Home and Boost*
 - 8 V = Boost
 - 10 V = Stopped
3. **Temperature setpoint**
Temperature setpoint (10-30 °C) corresponds to 0...10 V.
4. **Modbus**
Output is controlled with Modbus.

4.6 Smart Access

Unit can be controlled, monitored and commissioned with web service Smart Access*. Smart Access allows automatic alarm and service notifications through email. Smart Access provides unit specified links to spare parts and filter web shop and to Casahelp.

Installation

Install Smart Access device cable to unit internal connector or connect cable to SEC/SEM (Modbus and IO4). Connect Smart Access to public internet with ethernet cable (ETH connector).

Settings

If Smart Access is connected to internal connector no settings are required.

If Smart Access is connected to SEC/SEM module select Smart Access enabled in *Settings/(1234)/Modbus* menu.

Operations

Read the QR code from Smart Access device with smart device and follow the instructions.

Smart Access:

More information



*) Accessory

External connections diagram

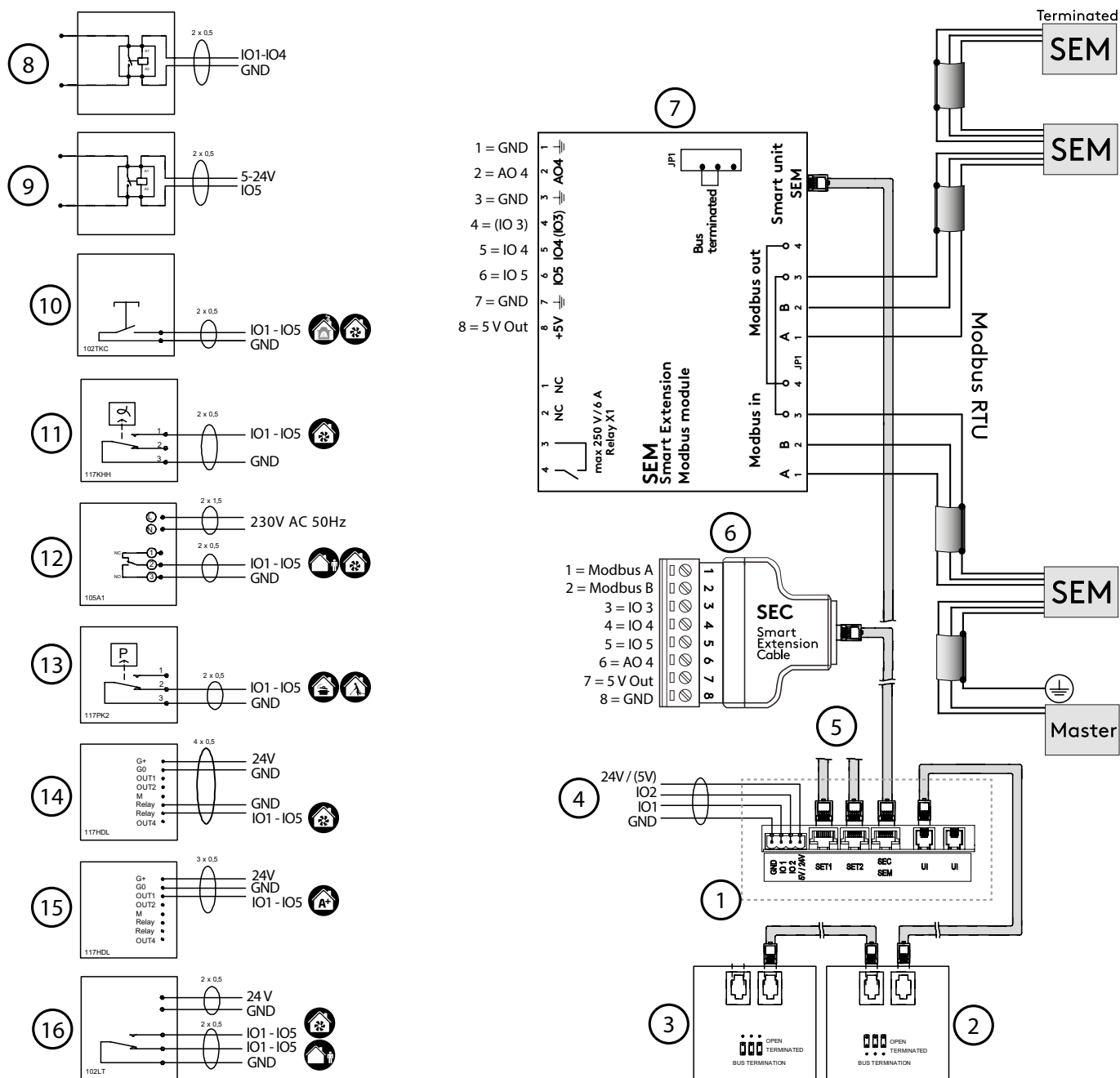

1. Air handling units external connections

- Swegon CASA Smart control panel (UP1)
- Swegon CASA Smart control panel (UP2)
- Connection points on the ventilation unit: IO1, IO2, 24 V / (5 V), selection from circuit board
- SET-module, Smart Extension Temperature module, connection card for external duct equipment
- SEC Smart Extension Cable, IO-extension cable with Modbus RTU (single point connector)
- SEM Smart Extension Modbus module, IO-extension module with relay and Modbus RTU (in and out connectors)
- External relay control, alarm signal, duct damper, status signal, Modbus
- External relay control (earthed output), alarm signal, duct damper, status signal, Modbus
- Fireplace/boost switch, for control of the fireplace function or boosting
- Humidity sensor, for control of boosting
- Timer, for control of the Away/Boost mode
- Pressure switch, for control of the cooker hood/central vacuum cleaner function.
- CO₂ sensor with relay, for activate the boost mode
- CO₂ sensor, for control of Automatic Home/Away/Boost system
- Presence sensor

5. Functions and use

This section contains functions detailed description, advanced settings and use. The advanced settings for the functions can only be accessed from Smart settings with password (1234 / changeable). The normal user settings can be limited.

In the User manual the functions are only covered from the user point of view. User settings are accessed from the Smart shortcut menu.

5.1 Functions

The Smart functions can be activated from the control panel shortcuts, Modbus or via external inputs. Some of the functions are so-called background functions which work by demand. Advanced settings can be accessed from the "Settings/(1234)/Smart functions" menu.

Note, some settings may not be visible depending units configuration.

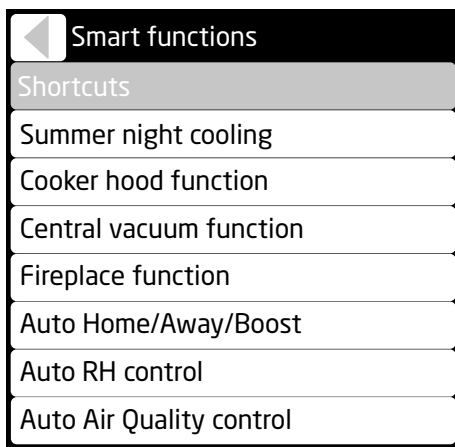

5.1.1 Shortcuts

From the "Shortcuts" menu you can set which functions are to be visible to the user. Boost selection effects to Auto RH control, Auto air quality, Auto Home/Away/ Boost functions which are available.

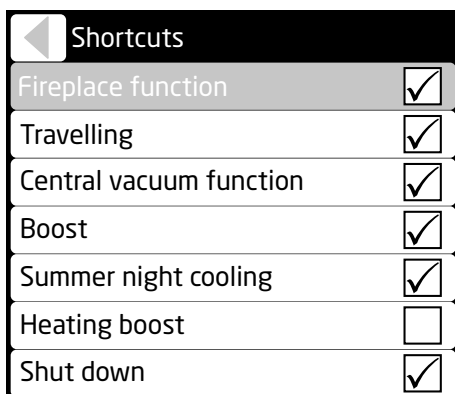

5.1.2 Summer night cooling

Automatic Summer night cooling detects cooling need and decreases the supply air temperature, if possible, and boosts the ventilation. Temperature control is applied with heat exchanger efficiency control and with external cooling battery (accessory). Summer night cooling is most efficient when the outdoor air temperature is relatively low.

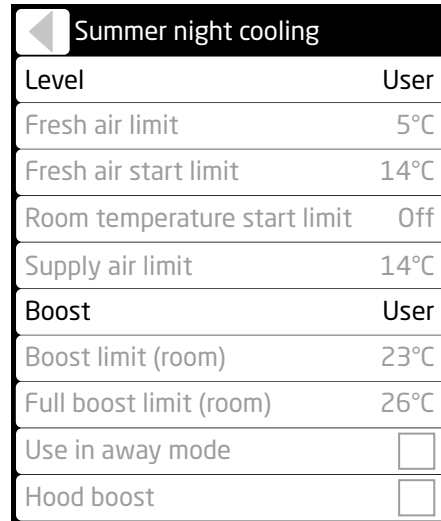

In the shortcut menu only preset level and Boost are selectable. To define advanced function settings select "User".

Summer night cooling level

Summer night cooling level is defined by cooling need detection limits and by lowering supply air temperature setpoint. With preset values the user can select cooling level: *off, low, normal, high* or *full*. *Fresh air limit* determines at which outdoor air temperature the function is allowed.

By default the cooling need is defined by outside temperature calculations and room temperature changes. If advanced settings (*User*) is selected the *fresh air start limit* can be changed which effects to the cooling detection limits.

If "*Room air temperature limit*" is selected, the cooling need is based on fixed *room temperature start limit*.

The supply air temperature setpoint is defined with *supply air limit* during function. If the limit is changed, the risk of condensation on the pipes must take into consideration.

Summer night cooling stepless boost

Summer night cooling effect is enhanced with boosting the ventilation if supply air temperature is relatively low. With preset values the user can select boosting level: *off, low, normal, high* or *full*.

If advanced settings (*User*) is selected the boost level can be defined with room temperature *boost limit* and *full boost limit*.

Select *Use in Away mode* to allow boost in Away mode.

Select *Hood boost* to open the damper on CASA Smart cooker hood when summer night cooling is active.

5.1.3 Cooker hood function

The cooker hood function balances the air flows when the cooker hood is used. This will help to prevent house negative pressure and improves fume extraction capability. The ventilation boost level during the function can be defined. The function starts automatically when the damper in a Swegon CASA cooker hood is opened or when a cooker hood defined IO is active.

The balancing is applied with increasing the supply air flow. If cooker hood is connected to separate extract duct and roof fan is selected the balancing is first decreasing the extract air flow and increasing the supply air flow if needed.

Commissioning and settings for the cooker hood function is described in Basic commissioning section.

5.1.4 Central vacuum function

The central vacuum function balances the air flows when the a central vacuum cleaner is used. This will help to prevent house negative pressure and improves the cleaning result. The function can be started by external switch connected to input configured as the CVC. The function will then be activated automatically when the central vacuum is on.

The function can also be started from a Smart control panel, the function runs until the set time has elapsed (*Run time*).

The function's settings can be adjusted from the *Settings/(1234)/Smart Functions/Central vacuum function* menu.

Central vacuum function	
Run time	30 min
Compensation	20%

The function's balancing level can be adjusted with the *Compensation* setting (max 50 %). The balancing is applied with first decreasing the extract air flow and increasing the supply air flow if needed.

5.1.5 Fireplace function

The fireplace function helps lighting the fire and ensures that no excess under pressure is generated. The function can be started from *Smart shortcuts* menu or by external switch connected to input configured as the fireplace function (IO-control).

Problems caused by too little draught in a fireplace usually occur in the autumn, when the temperature difference between the indoor and outdoor air is slight and the chimney is cold. The Fireplace function attempts to help the situation by giving a temporary positive pressure in the home when the fireplace is lighted.

After the lighting phase the function prevents the excess under pressure formation. The function *Run time* can be changed from the settings (max. 60 min). The function can be stopped from the control panel.

The function's settings can be adjusted from the *Settings/Smart Functions/Fireplace function* menu.

Fireplace function	
Run time	15 min
Speed difference	15 %

The function's maximum level can be adjusted with the *Speed difference* setting (max 25 %). The function is applied by demand with first decreasing the extract air flow and increasing the supply air flow if needed.

If problems occur with the chimney draught when lighting the fire, the percentage value can be increased slightly from the default value.

Use of the fireplace function repeatedly in extreme cold can cause forming of ice in the ventilation unit.

5.1.6 Automatic Home/Away/Boost function

The function is available only on models equipped with a CO₂ sensor. The function controls the ventilation steplessly between away and boost levels by demand. When the unit is controlled to away mode temperature setpoint can be decreased to save even more energy.

The function should always be adjusted to ensure optimal performance.

The function can be activated and adjusted from the *Settings/(1234)/Smart Functions/Home/Away/Automatic Boost* menu or from *Smart shortcuts* menu.

Auto Home/Away/Boost	
In use	<input checked="" type="checkbox"/>
A+ now	750 ppm
Home limit	700 ppm
Away limit	500 ppm

The function is adjusted by defining the CO₂ limits for Home and Away. When measured CO₂ value is between these values the air flow is controlled accordingly between Away and Home. If CO₂ value is above *Home limit* the air flow is boosted lineary and if CO₂ value is below *Away limit* the Away mode is activated.

A suitable *Home limit* value can be defined by reading the measured CO₂ level (*A+ now*) from the menu when a planned number of people are in the house. Similarly the *Away limit* value can be defined by reading the measured CO₂ level (*A+ now*) from the menu when a house is empty and the CO₂ level is settled.

The ventilation can be raised when people are at home by decreasing the *Home limit*. The away mode can be activated earlier by increasing the *Away limit*.

NOTE! The function is only visible if the CO₂ sensor has been detected.

NOTE! Measured CO₂ value depends on the ventilation system but the function is calibrated with the limits.

5.1.7 Automatic humidity control

The function is available only on models equipped with a humidity sensor. The function boosts the ventilation steplessly by demand. For example if humidity in the house rises due to showering.

If the humidity level (RH) remains above 60 % for a long period, we recommend that the ventilation is boosted and the humidity source is investigated.

The function can be activated and level selected from the *Settings/(1234)/Smart Functions/Auto RH control* menu or from *Smart shortcuts* menu.

Auto RH control	
Level	User
Boost limit	5 % + RH
Full boost limit	30 % + RH
Boost delay	0 min
Boost during delay	5 %

The user can select preset boost levels in the shortcut menu (*off, low, normal, high or full*). The preset levels define *Boost limit* and *Full boost limit*. To define these limits manually select "User" level.

The ventilation is boosted steplessly when the humidity has risen from average *Boost limit* defined amount. The maximum ventilation boost is reached when the humidity has risen the *Full boost limit* defined amount from the average.

The boost can be increased by decreasing the *Full boost limit*.

The boost start can be delayed with *Boost delay*. (The delay is started when humidity is stabilized after shower or sauna.) Fixed *boost level during the delay* can be defined.

NOTE! The function is only visible if the sensor has been detected. The function is enabled automatically when the sensor is detected.

NOTE! Humidity is measured from extract air and it represents average of the whole house.

5.1.8 Automatic air quality control

The function is available only on models equipped with VOC sensor. The function boosts the ventilation steplessly according to air quality level.

The function can be activated and level selected from the *Settings/(1234)/Smart Functions/Auto Air Quality control* menu or from *Smart shortcuts* menu.

Auto Air Quality control	
Level	User
AQ now	750 ppm
Boost limit	800 ppm
Full boost limit	1500 ppm

The user can select preset boost levels in the shortcut menu (*off, low, normal, high or full*). The preset levels define *Boost limit* and *Full boost limit*. To define these limits manually select "User" level.

The ventilation is boosted steplessly when the VOC has risen over *Boost limit*. The maximum ventilation boost is reached when the VOC has risen to the *Full boost limit*. Appropriate values can be established based on the *AQ now* value shown in the menu.

The boost can be increased by decreasing the *Full boost limit*.

NOTE! The function is only visible if the sensor has been detected.

NOTE! VOC measurement reacts on air quality changes and absolute value can vary highly but by selecting suitable boost level the function works effectively.

5.1.9 Weekly program

The ventilation unit's functions can be controlled with a maximum of four different weekly programs.

Operating mode and temperature for each program can be selected. Time limits and weekdays for the programs can be selected.

Smart boost can be disabled for a desired time, e.g. during the night by selecting Silent mode.

Weekly programs can be enabled and settings can be made from *Main menu/Weekly programs* menu.

NOTE! Program 1 has highest priority and program 4 lowest. Highest priority overrides other active programs.

Program 1	
State	Away
Temperature	17°C
Start time	07:00
Stop time	16:00
Monday	<input checked="" type="checkbox"/>
Tuesday	<input checked="" type="checkbox"/>
Wednesday	<input checked="" type="checkbox"/>
Thursday	<input checked="" type="checkbox"/>
Friday	<input checked="" type="checkbox"/>
Saturday	<input type="checkbox"/>
Sunday	<input type="checkbox"/>

5.2 Supply air temperature control

The supply air temperature is regulated by changing the temperature efficiency, with an integrated air heater or with an air cooler, which is sold as an accessory.

In **Eco mode** the ventilation unit works with the best possible temperature efficiency. It must be noted here that the higher the extract air temperature, the greater the direct effect will be on the supply air temperature. The supply air temperature can be adjusted if necessary by warmer supply air.

In **Comfort mode** the supply air temperature is kept even with the help of partially passing heat recovery, i.e. by controlling the temperature efficiency. It must be noted here that the unit is not able to produce supply air that is cooler than the outdoor air.

The control mode for the supply air is selected from the temperature control settings. The default mode is Eco.

The temperature setpoint can be adjusted using the control panel, weekly program, operating mode selection or based on room temperature.

Automatic summer night cooling recognizes the need for cooling. The function lowers the supply air temperature setting and bypasses the heat exchanger for best cooling performance. The unit can't produce cooler supply air than the outside air.

The unit can be equipped with an optional cooling coil, which allows active cooling of the supply air.

5.2.1 Temperature control settings

The user can change the temperature setting from the main menu. The preset value of the temperature setting refers to the supply air temperature that the unit attempts to reach. If room temperature regulation is selected, the setting value determines the setpoint value for the room temperature.

Supply temperature control settings can be accessed from the *Settings/(1234)/Heating / Cooling/Supply temperature control* menu.

Control method	
Control method	Supply air
Setpoint	17°C
Setpoint (away)	17°C
Setpoint (travelling)	16°C
Control mode	ECO

If control method *Supply air* is selected the base setpoint and lowered setpoints for Away and Travelling modes can be set. The heat exchanger *Control mode* can be selected.

Control method	
Control method	Room air
Supply control min value	17°C
Supply controller max value	17°C
Cooling min setpoint	14°C
Cooling max setpoint	25°C
Setpoint	21°C
Setpoint (away)	21°C
Setpoint (travelling)	20°C
Control mode	ECO

If control method *Room air* is selected min and max values for heating and cooling (if external cooling device* is installed) periods can be set. The room temperature control method aims to control room temperature by controlling supply air temperature between min and max values.

The Room temperature setpoint and lowered setpoints for Away and Travelling modes can be set. The heat exchanger *Control mode* can be selected.

NOTE! The Automatic summer night cooling can lower supply air temperature setpoint.

5.2.2 Temperature measurement

The supply and room temperature measurements can be fine tuned from settings menu (*Settings/(1234)/Heating / Cooling/Sensors / Controls*).

If SET module is attached supply, room, outside or water radiator temperature sensor inputs can be selected.

5.2.3 External heating & cooling units

Commissioning and setting of the heating and cooling equipment* connected to the ventilation unit are performed from *Settings/(1234)/Heating / Cooling* menu.

Detailed instructions are supplied together with accessories. By default the ventilation unit normally has internal post heating.

Heating / Cooling	
Adj. method	Supply air
Sensors / controls	
Int. post heater	<input checked="" type="checkbox"/>
Ext. post heater	<input type="checkbox"/>
Post heater out limit	8°C
Ext. post cooling	<input type="checkbox"/>
Ext. electric preheater	<input type="checkbox"/>
Ext. liquid coil	<input type="checkbox"/>



Important



Turning off the internal post heating or lowering the Post heater out limit is not recommended, due to the risk of condensation.

*) Accessory

5.3 Anti-frost protection

Anti-frost protection in the ventilation unit works automatically. The level of the anti-frost protection can be changed from the *Settings/(1234)/Defrost settings* menu.

◀ Defrost settings	
Level	Normal
Supply air limit	<input checked="" type="checkbox"/>
Supply air limit (min.)	14°C

Supply air limit function changes airflows if supply air temperature decreases below minimum limit or below setpoint.

5.4 Restoring factory settings

Resets all settings made from the control panel, except commissioned air flows.

5.6 Changing the settings password

Settings password can be changed from *Settings/(1234)/Change service code* menu. By changing the service code commissioned functions can be protected. Changed password is possible to reset (Casahelp).

◀ Enter code
[1 2 3 4]
Accept

5.7 Use

The instructions for normal use is described in user manual supplied with the unit.

The unit is designed to work automatically once the unit is commissioned. Normal use case is that operating mode is selected. This can be done automatically with Smart sensors.

6. Service

6.1 Service reminder

The service reminder is activated with preset time intervals and the ⓘ symbol is displayed on the control panel's screen and cooker hood indication LEDs. As a factory setting, the service reminder is not in operation. It can be activated from *Main menu/Diagnostics / Service reminder* menu. The recommended service interval for the ventilation unit is six months.

When servicing has been performed, the service reminder is reset from "Alarm" in the main menu. Service reminder can always be reset under the main menu item "Diagnostics / Service reminder".

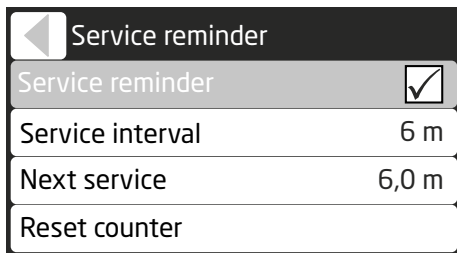

6.2 To open the ventilation unit

Before beginning any service work, isolate the power supply voltage by removing electric plug. Wait a few minutes before you open the inspection door of the ventilation unit so that the fans have time to stop and possible air heaters to cool down.

The inspection door can be opened by turning the lock bolts with a slotted screw driver. Support the top edge of the door with one hand when you open the lock bolts.

Turn the service switch to the 0-position prior to commencing servicing.

6.3 Filters

The filters should be replaced at least every six months. The filters may need to be replaced more often in homes where there is considerable dust or if there are many impurities in the outdoor air.

In a new home, there is still moisture from the construction period, and the filters can become soiled more quickly than usual. The first filter change should therefore be made more often.

The ventilation unit must not be operated without filters. Use only filters recommended by Swegon.

This is important, as filters with exactly the same appearance and size can have very different pressure losses and filter capacity. If an incorrect filter is used, the ventilation unit may not work as designed and Swegon can't be responsible for possible malfunction. Check correct filters from the list of components.

How to change filters, instruction video:

www.swegonhomesolutions.com
Toolbox / How to change a filter



6.4 Heat exchanger

Check the condition of the heat exchanger whenever servicing the unit.

Carefully rotate the heat exchanger rotor one revolution to inspect the condition of the drive belt. Do not damage the heat exchanger fins.

Check the condition of the brushes along the rotor periphery.

6.5 Fans

The ventilation unit's fans must be checked at least every two years.

Dismantling the fans for cleaning (qualified service personnel only)

- Remove the filters from the ventilation unit.
- Open two wing screws on the fans.
- Pull out the fan.
- If the fans are pulled out completely, cut the cable tie and disconnect the quick-fit connector.
- If necessary, clean the fan with a soft brush. Be careful not to dislocate the fans balancing weights. If significant amounts of dirt collect on the fan cleaning should be left to a professional.
- Reinstall the fan cable and secure connection with cable tie.
- Push the fan back and lock it in with wing screws.
- Remember install the filters.

The ventilation unit's fans must be removed, while the ventilation ducts are cleaned.

6.6 Other servicing

Clean the inner surfaces of the ventilation unit by vacuum cleaning or with a damp cloth, if needed.

Check that dirt has not collected on the surfaces of the air heater, clean if necessary.

Check that the ventilation unit works normally and that no alarms are shown on the screen.

Service check list

Every six month

- Change filters, reset service reminder
- Clean the inner surfaces
- Check alarms from user panel
- Clean the cooker hood crease filter

Every 2 years

- Check and clean fans

Every 10 years

- Clean the ducts
- Check and adjust the air flows

6.7 Diagnostics

Unit operation can be monitored from *Main menu/ Diagnostics* menu.

- **Service reminder.**
Service reminder activation and service interval setting. The menu also displays the time for the next service.
- **Temperatures.**
The temperature values shown in the menu vary according to which sensors are used in the unit.
NOTE! Fresh air temperature is measured inside the unit and it may not correspond to outside temperature.
- **Smart functions.**
The values shown in the menu vary according to which Smart sensor is used in the unit.

Smart functions	
A+	830 ppm
AQ	770 ppm
RH	41 %
AH	11,8 g/m ³
AH setpoint	12,6 g/m ³
A+ control	-3 %
RH control	0 %
AQ control	4 %
Smart control	1 %

The A+, AQ and RH corresponds CO₂, VOC and humidity measurements. The AH and AH setpoint are absolute humidity values used by auto humidity control. Humidity boost starts when AH is above AH setpoint.

The control information shows how much different automatic Smart functions boost the ventilation with respect to Home mode. The "Smart control" value shows the total boost effect for all Smart functions.

- **Fan speeds.**
The menu shows the fan control values and measurements.
- **Heating and cooling.**
The heating and cooling controls, the supply air setting and the supply air temperature are shown on the menu. In addition, the menu displays indicators for the capacity of the summer night cooling and preheating.
- **Anti-frost protection.**
Operating status for automatic defrosting and supply air limiting.
- **External control functions.**
The menu includes external input statuses.

Swegon CASA R2 Smart L

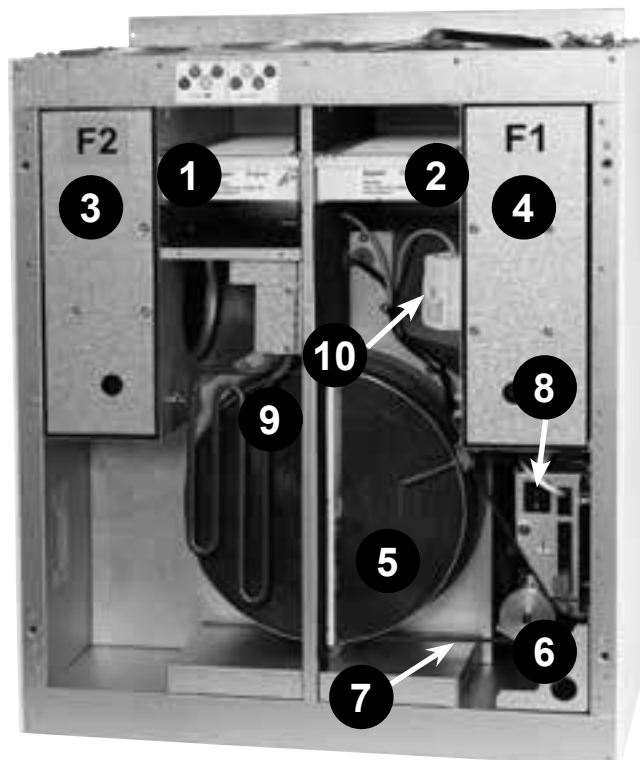

Swegon CASA R2 Smart R

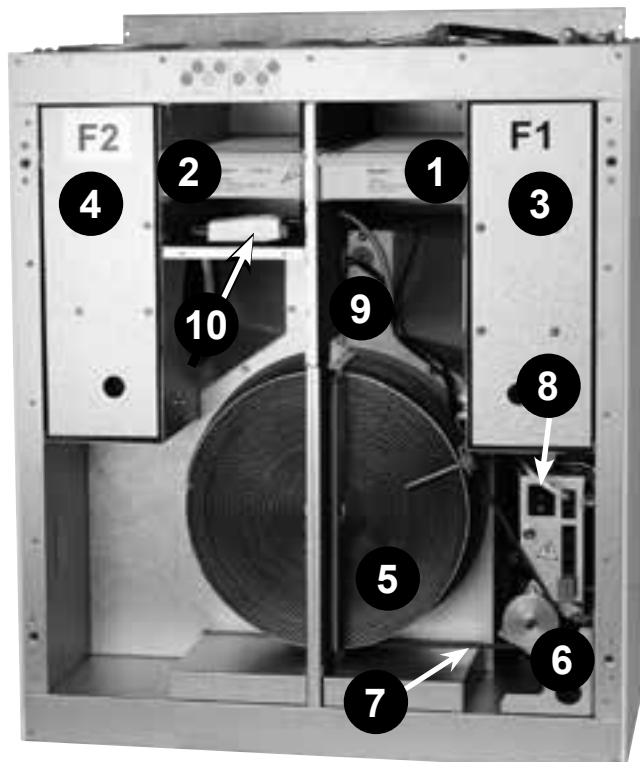

1. Supply air filter
2. Extract air filter
3. Supply air fan
4. Extract air fan
5. Heat exchanger
6. Heat exchanger motor
7. Heat exchanger drive belt
8. Service switch
9. Post heater (not visible in right-hand version)
10. Sensor package

7. Alarms and Troubleshooting

The unit has inbuilt diagnostics for malfunction and protective functions to prevent damage. Malfunction is indicated with alarm in cooker hood, user interface and with digital relay outputs. This section contains description of alarms, actions and troubleshooting. Most of the actions listed in alarm description table is allowed only for qualified person with needed permissions.

7.1 Alarm indication, cooker hood

If the ventilation unit detects critical alarm, all signal lamps on the cooker hood blinks three times every 30 seconds.

Following alarms are indicated:

- Sensor fault
- Supply air hot
- Internal overheat
- Supply air cold
- Water radiator freezing protection shutdown
- Repeating post heater fail
- Repeating preheater fail

NOTE! The service reminder is indicated with one blinking damper timer signal lamp.

7.2 Alarm indication, control panel

If the ventilation unit detects alarm or info message it is indicated in the user panel main screen. The symbol for an active alarm is **▲**. The malfunction that has caused the alarm is shown in the menu (*Main menu / Alarm*). Info message ⓘ indicates unconfirmed alarms when the malfunction is fixed. Info message also indicates the set service interval has elapsed. The Info message can be reset from the *Alarm* menu.

! Important !

Frost protection function
Ice can form in the heat exchanger during periods of cold weather if the extract air is humid. A protective function then automatically reduces the speed of the supply air fan. Under such conditions, variations in the fan speed are therefore normal. Under such conditions, small amounts of ice can form inside the ventilation unit.

7.3 Troubleshooting

Troubleshooting and service instructions:

www.casahelp.fi



A ventilation system is composed of several system components which all influence how the system operates. A malfunction in ventilation performance could be caused by any system component or fail in installation, commissioning or service.

The unit warranty is valid during the warranty period if unit installation, commissioning and service is done according this manual. If despite proper usage there are functional disruptions in the ventilation unit, register these using the response form at the address www.casahelp.fi.

There are also instructions, service videos and frequently asked questions on the same website. You directly access a web page with model specific instructions by reading the QR code on the door of the ventilation unit with a smartphone.

If a problem or a fault occurs on the ventilation system after the warranty period, contact our network of authorised service companies on www.swegonhomesolutions.com, your real estate company's service division or another service company that is fully conversant with ventilation repairs.

7.4 Alarm descriptions

*) Indicated in Smart cooker hood

Alarm	Modbus register - bit (LSB)	Cause	Action
T1, T2...T9 sensor fault*	⚠ 3x6136-6 ℹ 3x6137-6	Sensor reading is out of range.	The ventilation unit runs in a restricted operating mode. Check cable connections and configuration. Change sensor if faulty.
Post heater fail (*)	⚠ 3x6136-0 ℹ 3x6137-0	Post heater control diagnostics has detected open circuit or control fail.	The ventilation unit runs normally but post heating may not work. Check manual overheating protection. Check post heating circuit.
Preheater fail (*)	⚠ 3x6136-1 ℹ 3x6137-1	Preheater control diagnostics has detected open circuit or control fail.	The ventilation unit runs normally but preheating may not work. Check manual overheating protection. Check preheating circuit.
Water radiator freezing warning	⚠ 3x6136-3 ℹ 3x6137-3	Water temperature is critically low (12 °C) and outdoor temperature is below 0 °C.	The ventilation unit runs normally but freezing protection is activated (electrical heater is activated and valve is fully opened). If water temperature is below 10 °C the unit is stopped. Unit is started when water temperature rises over 15 °C. Ensure that the heating system circulation pump is running and the water is warm.
Supply fan fail	⚠ 3x6136-4 ℹ 3x6137-4	No fan speed signal.	The ventilation unit runs normally. Check fan and cabling.
Extract fan fail	⚠ 3x6136-5 ℹ 3x6137-5	No fan speed signal.	The ventilation unit runs normally. Check fan and cabling.
Connection fail		Control panel does not communicate with ventilation unit.	Restart the ventilation unit. Check cabling. Test other connector.
Emergency stop	⚠ 3x6136-7	Emergency stop or emergency stop resettable input activated.	The ventilation unit is stopped by the emergency stop function. The emergency stop alarm is reset and unit is started when the input is deactivated. The emergency stop resettable alarm is reset from user panel.
Internal failure	⚠ 3x6136-10 ℹ 3x6137-10	Internal temperature critical high. Memory read error.	The ventilation unit runs in a restricted operating mode. Restart the ventilation unit.
Rotor fail	⚠ 3x6136-14 ℹ 3x6137-14	No rotor speed signal.	The ventilation unit runs normally. Check rotor motor, belt and cabling.
Fan control	⚠ 3x6136-15 ℹ 3x6137-15	Constant duct pressure control error.	The ventilation unit runs normally but without constant duct pressure control. Check pressure measurement and settings in commissioning mode.
Supply air hot*	⚠ 3x6136-12 ℹ 3x6137-12	Supply air temperature critical high (50 °C).	The ventilation unit runs normally but all electrical heaters are controlled off. Inspect the cause for high temperature. Do not use the unit before problem detected and fixed.
Supply air cold*	⚠ 3x6136-11 ℹ 3x6137-11	Supply air temperature critical low (10 °C) over 5 minutes.	The ventilation unit is stopped. The unit is started when supply temperature rises over 10 °C.
Internal overheat	⚠ 3x6136-13 ℹ 3x6137-13	Internal temperature critical high (50 °C).	The ventilation unit runs normally but all electrical heaters are controlled off. Inspect the cause for high temperature. Do not use the unit before problem detected and fixed.
Elect. pre-heater fail	⚠ 3x6136-2 ℹ 3x6137-2	External electrical pre-heater control fail.	The ventilation unit runs normally. Check over heating protection, cabling and settings.
External alarm	⚠ 3x6138-1	External alarm input is active.	The ventilation unit runs normally.
Service reminder*	ℹ 3x6137-9	Service interval has elapsed.	Service the ventilation unit and reset the service reminder.

8. Technical data

8.1 List of components

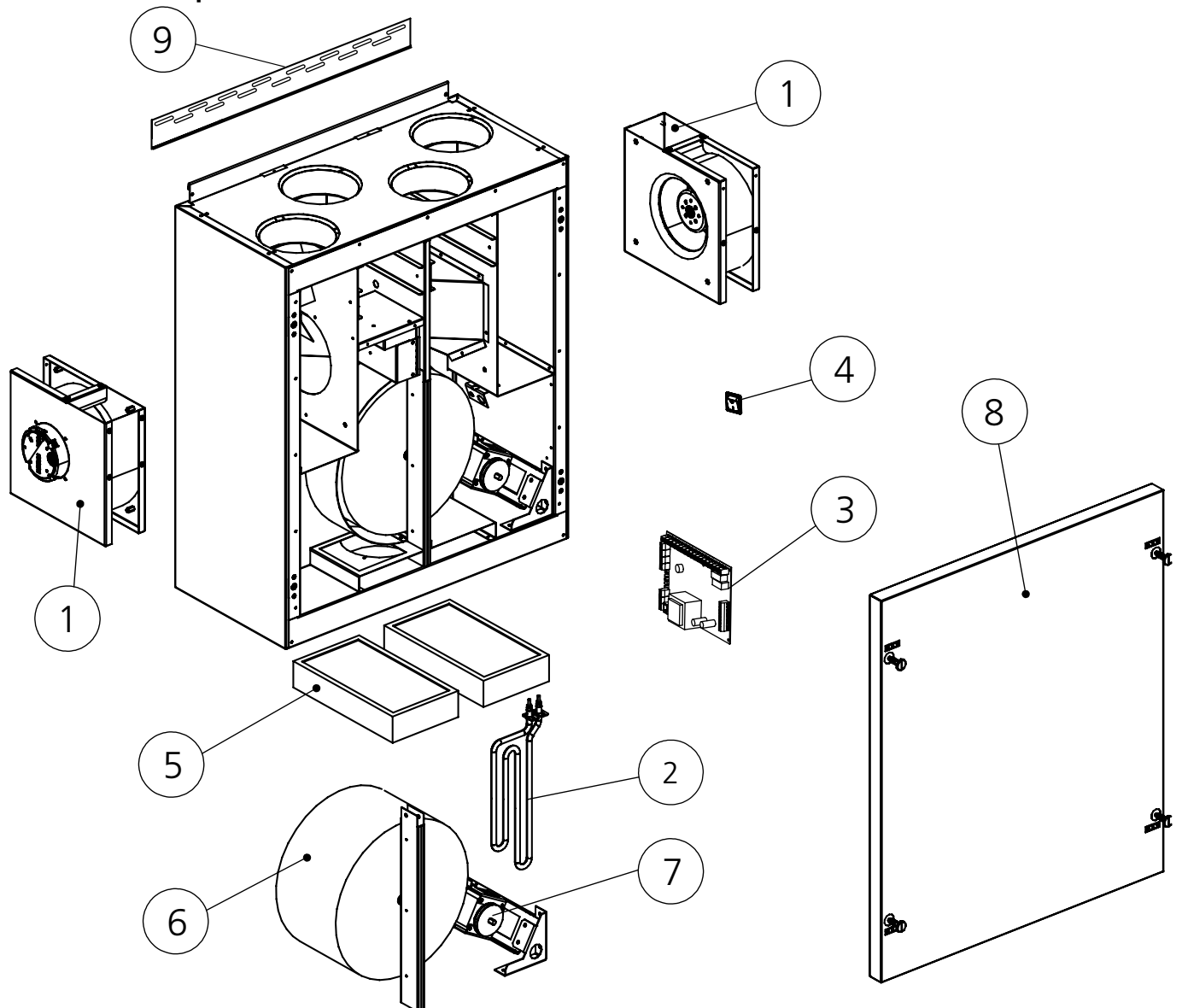

1. Fan (without housing): R000080
2. Post heater:
 - 400 W, (R-model): R000099
 - 400 W, (L-model): R000099-1
 - 700 W, (R-model): R000100
 - 700 W, (L-model): R000100-1
3. EC circuit board: R000091
4. Service switch: 50319
5. Set of filters (2 x F7): R02FS
6. Heat exchanger: R000013
7. Rotor motor: R000012-1
8. Door: R000082
9. Wall mounting bracket: R000083

Accessories

- Smart control panel: SC10
- Extension frame for control panel: TB00301
- Modular cable: PMK20
- Filter replacement kit: R02FS
- Duct plug and insulation plate: R000040
- Front panel:
 - White: TB00015
 - Black: TB00015S
 - Stainless: TB00018
- Kitchen door installation kit, magnet: TB00316
- Upper extension part for unit:
 - White: R02EPW
 - Stainless: R02EPS
- Smart sensors:
 - RH: SRH
 - RH + CO₂: SRHCO2
 - RH + VOC: SRHVOC

Buy online:

www.casabutiken.se
www.casastore.fi



8.2 Airflows (EN 13141-4)

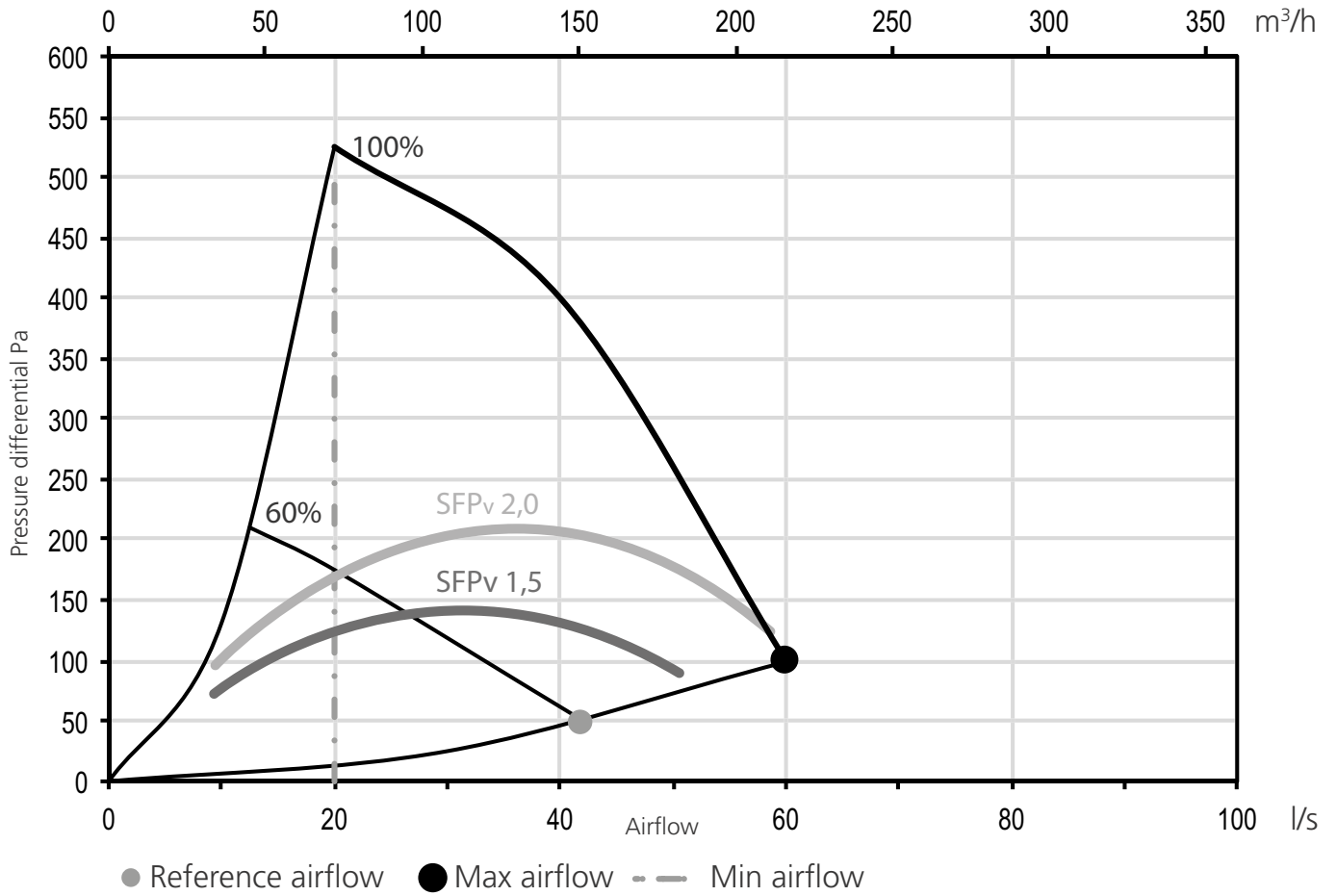

8.3 Outputs of the components

	R2 400 W	R2 700 W
Connection	230 V, 50 Hz, 2,9 A	230 V, 50 Hz, 4,2 A
Fans	234 W	234 W
Heat exchanger motor	10 W	10 W
Air heater, reheating	400 W	700 W
Total output	654 W	954 W

8.4 Acoustic data

Acoustic data can be found from ProCASA.

procasa.swegon.com



8.5 Electrical wiring diagram

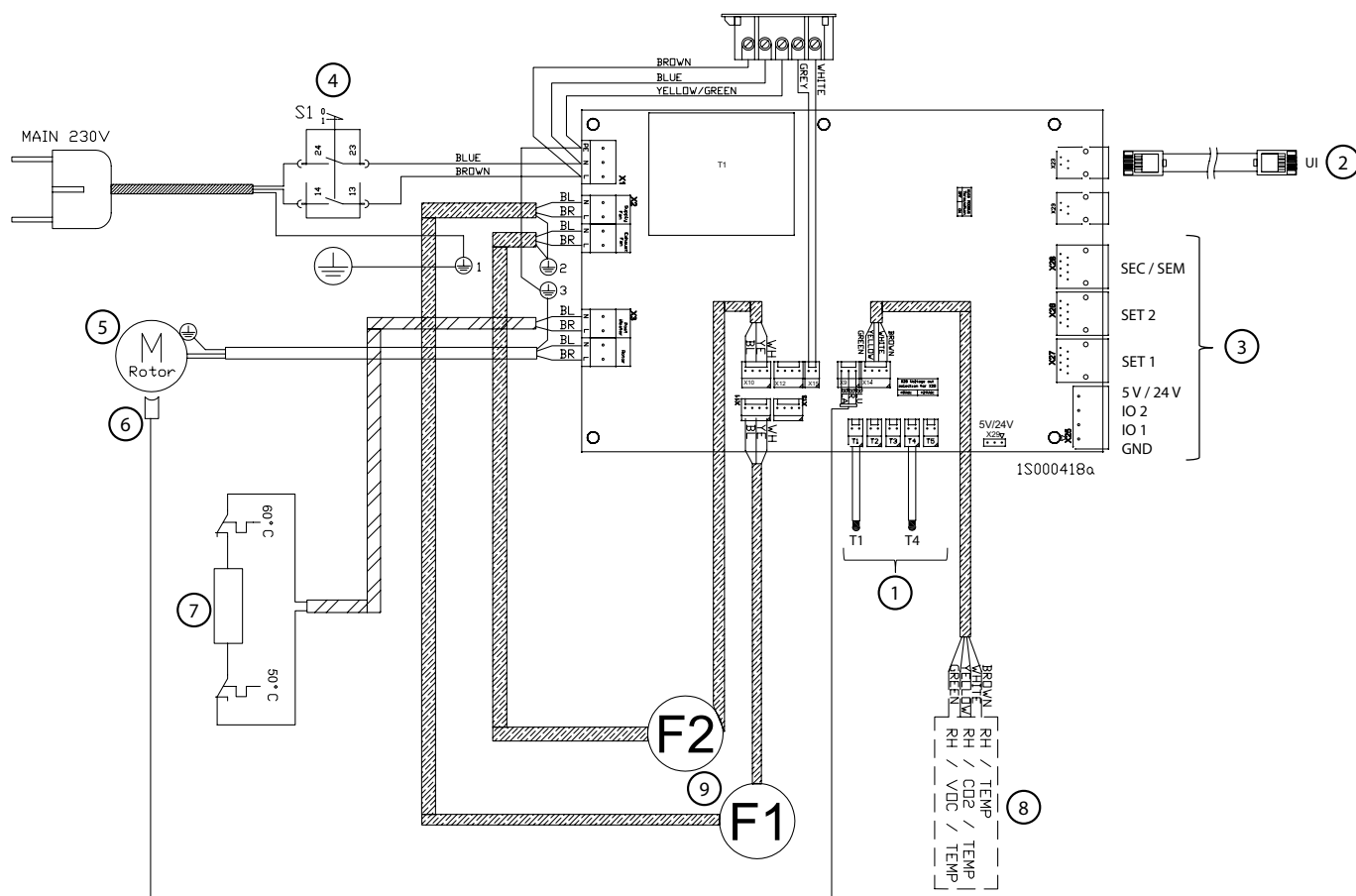

1. Temperature sensors:
 - T1 Outdoor air temperature*
 - T4 Supply air temperature*
2. Connector for the Smart control panel.
3. External connections. See the section "Units external connections".
4. Service switch
5. Rotor motor
6. Proximity sensor
7. Post heating air heater (400 W / 700 W)
8. Smart sensor package
 - RH + Extract air temperature*
 - RH + Extract air temperature + CO₂ (accessory)*
 - RH + Extract air temperature + VOC (accessory)*
9. Fans
 - R-unit**
 - F1 Supply fan*
 - F2 Extract fan*
 - L-unit**
 - F1 Extract fan*
 - F2 Supply fan*

8.6 Control diagram

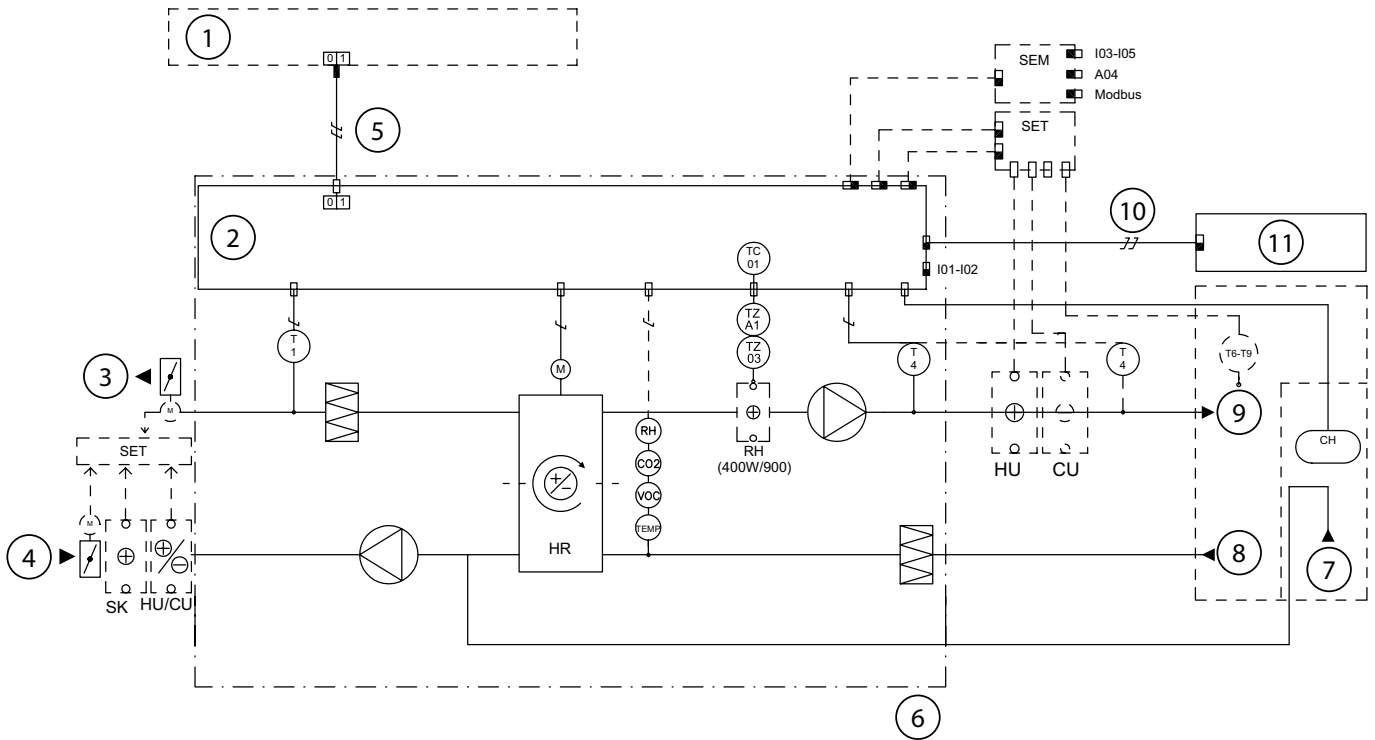

1: Group electrical distribution box | 2: Electrical equipment cubicle | 3: Exhaust air | 4: Outdoor air | 5: Power supply: 230 V, 10 A with plug-in connection | 6: Supply demarcation of the ventilation unit | 7: Extract air from cooker hood | 8: Extract air | 9: Supply air | 10: Modular cables with RJ9-connectors | 11: Control panel

SYMBOL	DESIGNATION	EXPLANATION
TC01	THERMOSTAT	Post heater control / control diagnostics
T1	TEMPERATURE SENSOR	Temperature sensor, outdoor air
T4	TEMPERATURE SENSOR	Temperature sensor, supply air.
T6-T9	EXTERNAL TEMPERATURE SENSOR	Connected to SET, the functions are determined through the programming of SET (accessory)
TZ03	OVERHEATING PROTECTION	Overheating protection with manual reset
TZA1	OVERHEATING PROTECTION	Automatic over temperature protection
CH	COOKER HOOD SWITCH	Cooker hood function
SET	CONNECTION UNIT	Smart Extension Temperature module, accessory
SEM	CONNECTION UNIT	Smart Extension Modbus module, accessory
HR	HEAT EXCHANGER	Heat exchanger
SD2	DAMPERS	Shut-off dampers, accessory
SK	AIR HEATER	External electric preheater, accessory
HU	AIR HEATER	External air heater, accessory
CU	AIR COOLER	External air cooler, accessory
RH	SENSOR	Humidity sensor
CO2	SENSOR	Carbon dioxide sensor, accessory
VOC	SENSOR	VOC sensor, accessory
TEMP	SENSOR	Temperature sensor, extract air

DESCRIPTION OF THE FUNCTIONS

CONTROL FUNCTIONS:

The ventilation unit can be operated from a separate Smart control panel or a Smart cooker hood.

When the ventilation unit is controlled from the cooker hood in the Home/Away/Boost modes and cooker hood damper open time can be set to 30, 60 or 120 minutes. (For Disco, up to Max 60 min.)

The supply air temperature setpoint can be changed from the Smart control panel. The post heating can be disabled from the control panel.

SAFETY FUNCTIONS:

- Overheating protection for the post heater: Electrical heater is equipped with a automatic thermostat TZA1 and a thermostat TZ03 with manual reset (set value 60 °C).
- The fans have automatic overtemperature protective devices.

REMEDIAL MEASURES TO TAKE IF THE SAFETY EQUIPMENT TRIPS:

- If an overheating protection with manual reset trips, locate and correct the fault; then press the reset button inside the ventilation unit.
- The automatic overheating protections of the fans will reset themselves when the temperature has dropped below the setting value.

REMOTE OPERATION: Study the ventilation unit manual and the list of parameters for Modbus.

8.7 Dimensions

Swegon CASA R2

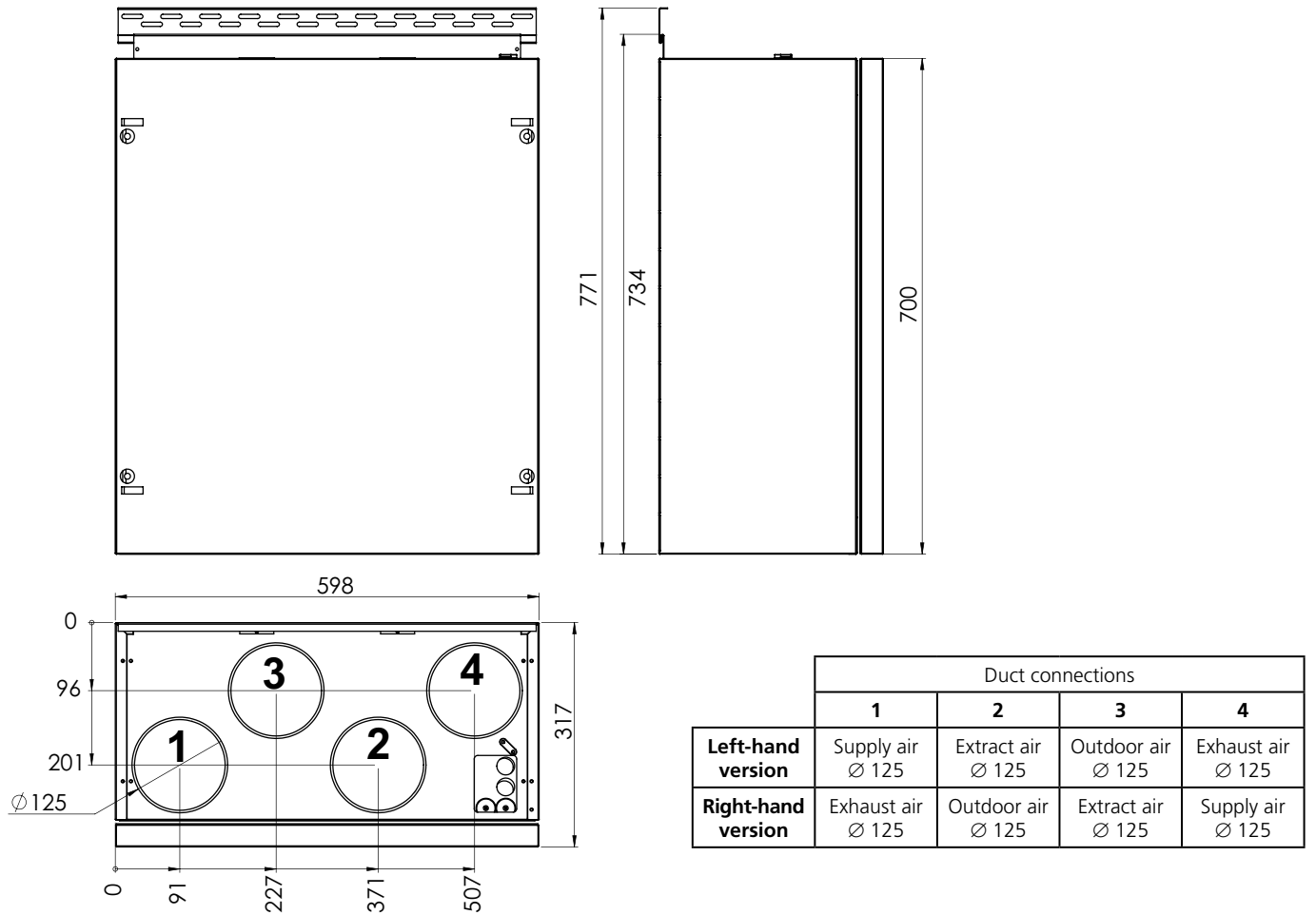

Swegon CASA Dance

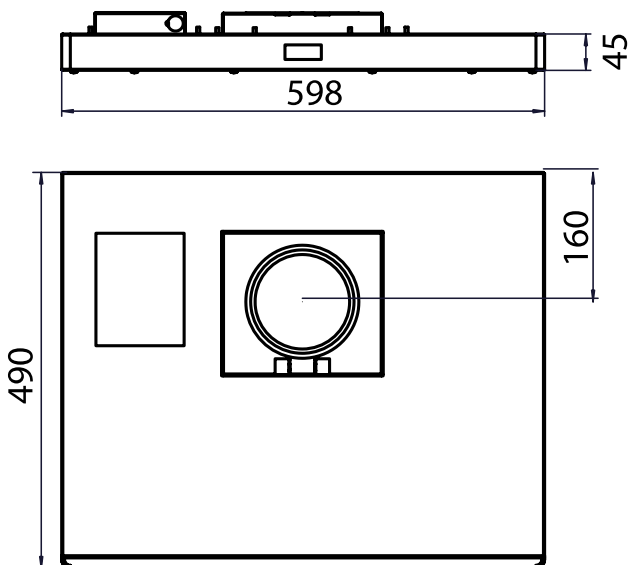

Swegon CASA Disco

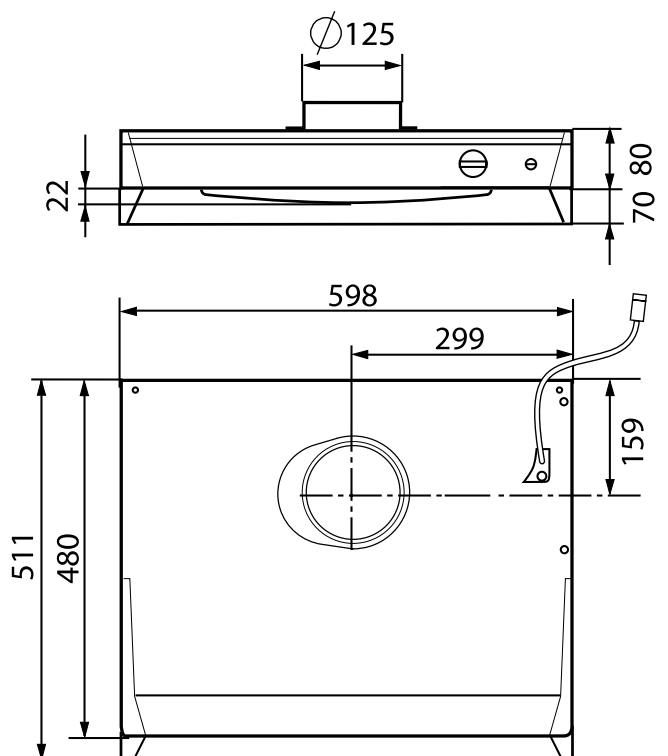

8.8 Weights

- R2 ventilation unit: 45 kg.
- R2 + CASA Jazz M cooker hood: 52,5 kg.
- R2 + CASA Dance cooker hood: 51 kg.

8.9 Ventilation unit codes

- | | |
|--------------------|-------------|
| • R2 Smart L 400 W | R02VL04S00H |
| • R2 Smart R 400 W | R02VR04S00H |
| • R2 Smart L 700 W | R02VL07S00H |
| • R2 Smart R 700 W | R02VR07S00H |

8.10 Accessories for installation

- **Smart control panel** (SC10). Smart control panel with Exxact frame.
- **Smart humidity sensor** (SRH). For Auto humidity control.
- **Smart CO₂ + humidity sensor** (SRHCO₂). For Auto Home/Away/Boost function and Auto humidity control.
- **Smart VOC + humidity sensor** (SRHVOC). For Auto Air Quality control and Auto humidity control.
- **Smart Extension Modbus module** (SEM). IO-extension module with relay and Modbus RTU (in and out connectors).
- **Smart Extension Cable** (SEC). IO-extension cable with Modbus RTU (single point connector).
- **Humidity switch** (117KKH). For the Boost operating mode activation.
- **Fireplace function switch** (102TKC). A push button or remote Fireplace function activation.
- **Presence sensor** (102LT). For Boost or Away mode activation by movement detection.
- **Operation mode switch**. (any potential free switch) For Travelling, Away, Home or Boost mode activation.
- **External CO₂ sensor** (117HDL). For Auto Home/Away/Boost function.
- **Pressure switch** (117PK2). For cooker hood or central vacuum cleaner function activation if state signal is not available.

Air cooler for cooling the supply air

- For 160 mm ducts; SDCW 160
- For 200 mm ducts; SDCW 200
- For 250 mm ducts; SDCW 250F

Air heater for heating the supply air

- For 125 mm ducts; SDHW 125
- For 160 mm ducts; SDHW 160

Air heater in combination with ground source heat pump

- For 200 mm ducts; SDHW 250F

Electric air heater for outdoor / supply air duct

- For 125 mm duct; SDHE125-1T
- For 160 mm duct; SDHE160-1T
- For 200 mm duct; SDHE200-1T

Commissioning form

Function	Planned air flow	Default	Setting
Basic air flows	l/s m³/h	%	%
Home (supply)		50 %	
Home (extract)		70 %	
Away (supply)		20 %	
Away (extract)		40 %	
Boost (supply)		65 %	
Boost (extract)		85 %	
<i>Travelling (supply)</i>		20 %	
<i>Max Smart boost (supply)</i>		65 %	
Cooker hood function			
<i>Home state compensation (difference)</i>		10 %	
<i>Boost state compensation correction (difference)</i>		0 %	
<i>Hood boost (supply)</i>		70 %	

Commissioned ventilation unit serial number | User panel: Main menu/Information/Serial number.

Commissioned by:	Date:



Asennus-, käyttöönotto- ja huolto-ohje

https://serviceportal.swegon.com/fi/docs/TM_R2_FI



**Installations-, Inbetriebnahme- und
Wartungsanleitung**

https://serviceportal.swegon.com/fi/docs/TM_R2_DE



**Installations-, drifttagnings- och
underhållsanvisning**

https://serviceportal.swegon.com/fi/docs/TM_R2_SE



**Installation, commissioning and
maintenance instructions**

https://serviceportal.swegon.com/fi/docs/TM_R2_EN



**Installasjons-, igangkjørings- og
vedlikeholdsveiledning**

https://serviceportal.swegon.com/fi/docs/TM_R2_NO

Feel good **inside**